

GEFÖRDERT VOM



Bundesministerium
für Bildung
und Forschung



Hunting the Invisible -- Searches for Dark Matter at the LHC

Kerstin Hoepfner, RWTH Aachen, III. Phys. Inst. A

DESY Seminar February 11th 2014

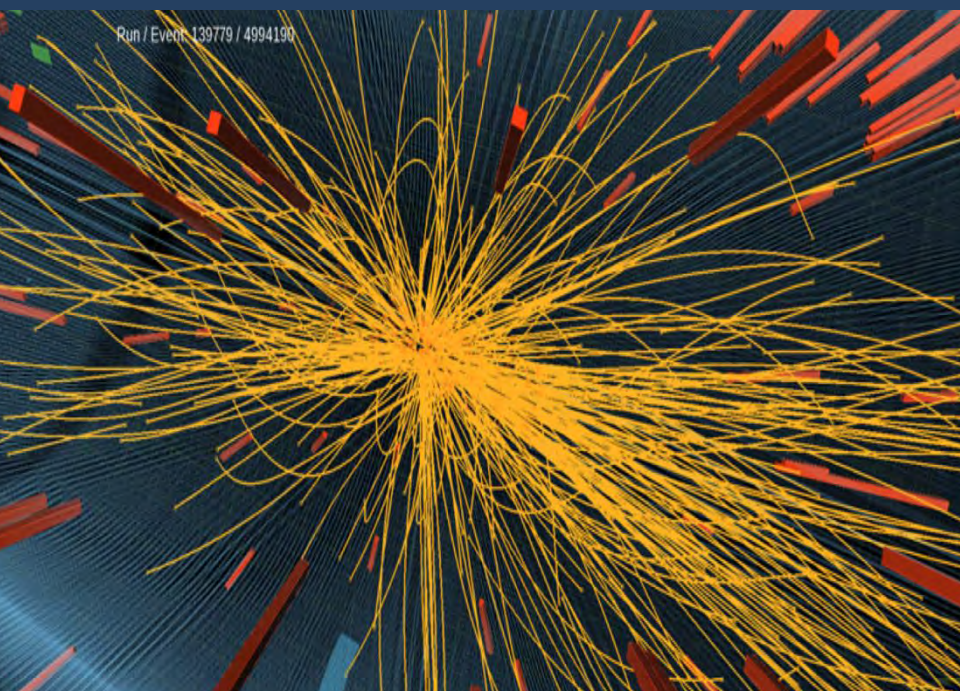



Outline

1. **Signatures of Dark Matter at the LHC**
2. **Detection in CMS and ATLAS**
3. **Monojet (historically leading channel)**
4. **Monophoton**
5. **Mono-boson**
 - **Leptons (access to u/d-type couplings)**
 - **Hadronically decaying W/Z (max. sensitivity)**
6. **The big picture**

Indications for Dark Matter

- Astrophysical measurements point to existence of **non-baryonic form of matter** (DM)
→ one compelling evidence for physics beyond Standard model (SM)

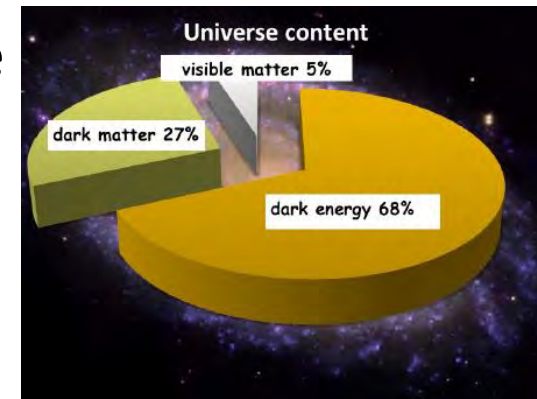

Rotation curves of galaxies

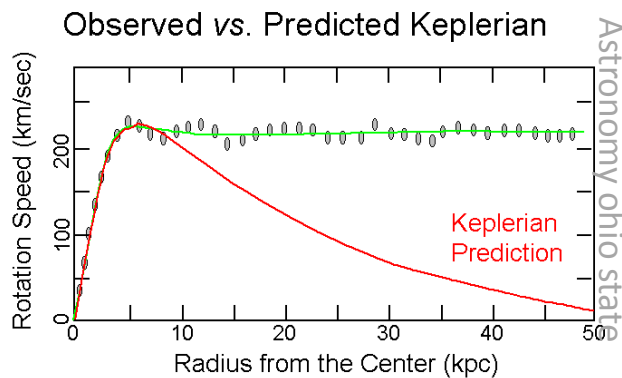

Gravitational lensing

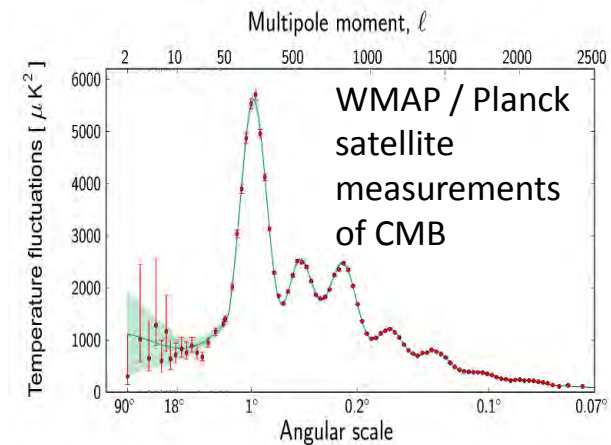

- Increasing number of observation consistent with DM existence
- **No direct observation yet**

DM Properties

No direct observation of DM yet

Most popular class of candidates to explain observations suggests **properties**:

- **Fermionic** matter
- Interacts only **weakly**
- **Massive** particles (GeV \rightarrow TeV)
- Expected to be **neutral**
- **Cold**: non-relativistic

Dark matter = part of cosmological SM

Requires beyond SM physics

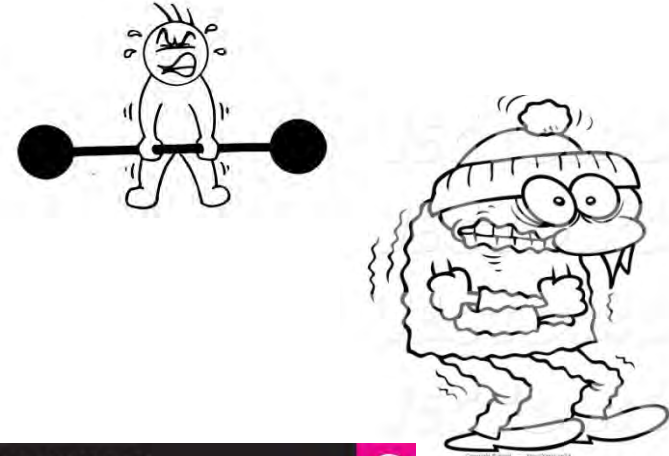

DARK MATTER ?

DARK MATTER is the name given to material in the Universe that does not emit or reflect light but is necessary to explain observed gravitational effects in galaxies and stars. Dark matter, along with dark energy, totals 96% of the Universe, yet it remains a mystery as to what exactly it is.

Acrylic felt, wool felt, and fleece with gravel fill for maximum mass.

Packaged in a black opaque bag designed for concealing contents.

\$10.49 PLUS SHIPPING

LIGHT HEAVY

GLUON PHOTON NEUTRINO TACHYON ELECTRON UP QUARK DOWN QUARK TAU NEUTRINO MUON UP QUARK
NEUTRINO DOWN QUARK TAU GLUON **DARK MATTER** NEUTRINO TACHYON ELECTRON UP QUARK DOY
NEUTRINO MUON UP QUARK PROTON NEUTRINO DOWN QUARK TAU GLUON PHOTON NEUTRINO TACHY
The **PARTICLE ZOO** TAU NEUTRINO MUON UP QUARK PROTON I
ELECTRON UP QUARK DOWN QUARK TAU NEI

Detecting Dark Matter

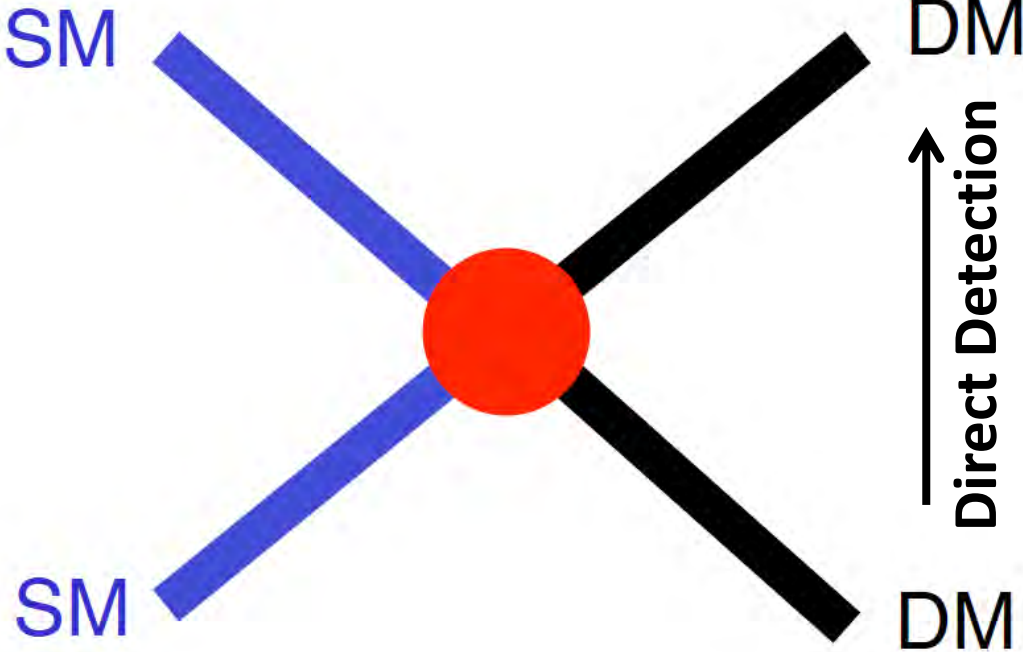

↑
Direct Detection

Scattering of DM particles on nuclei of detector material; detect recoil.
For a given cross section sensitivity scales with detector size.

Result is Not Conclusive...

Wealth of direct detection experiments.
WIMP search status < October 2013

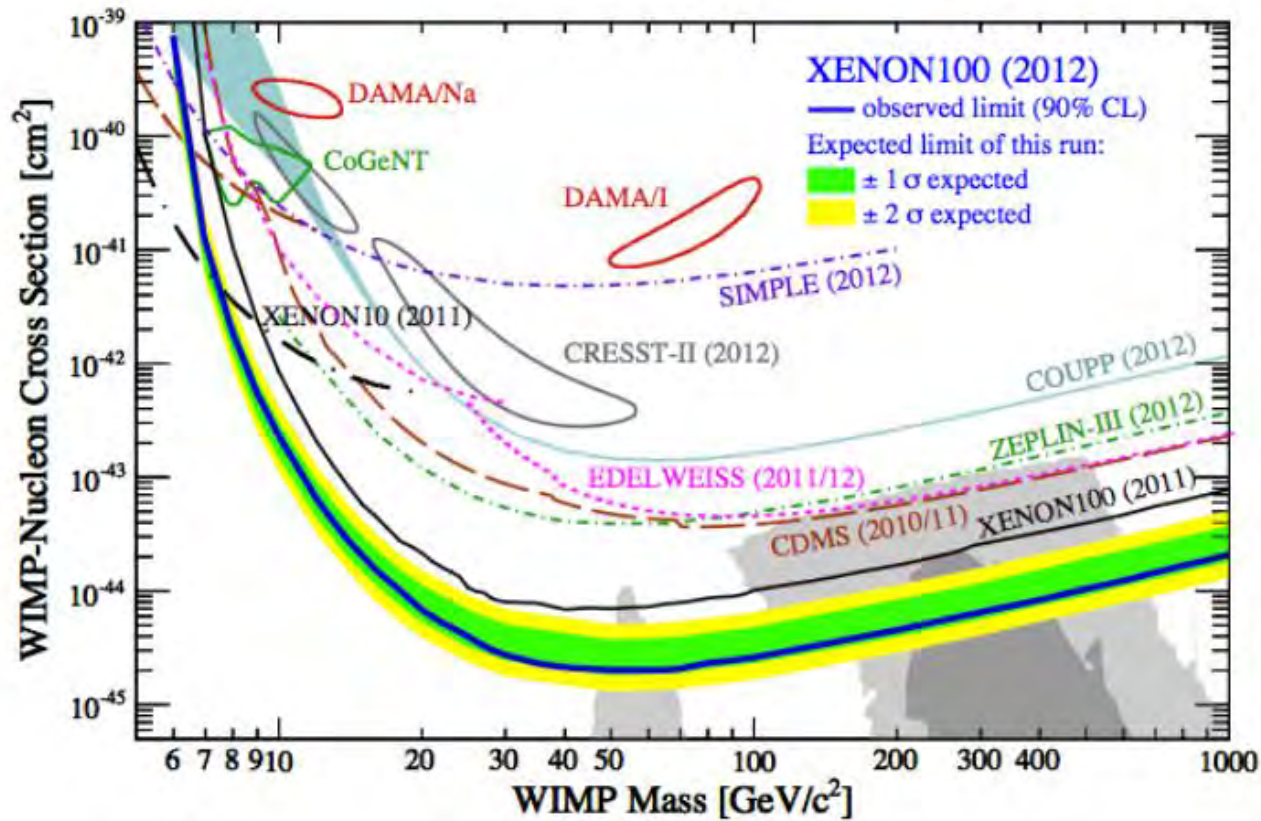

90% CL

[Xenon coll.: arXiv:1207.5988](https://arxiv.org/abs/1207.5988) [astro-ph.CO]

Detecting Dark Matter

Assume annihilation of DM particles, e.g. in the sun. Detect annihilation products.

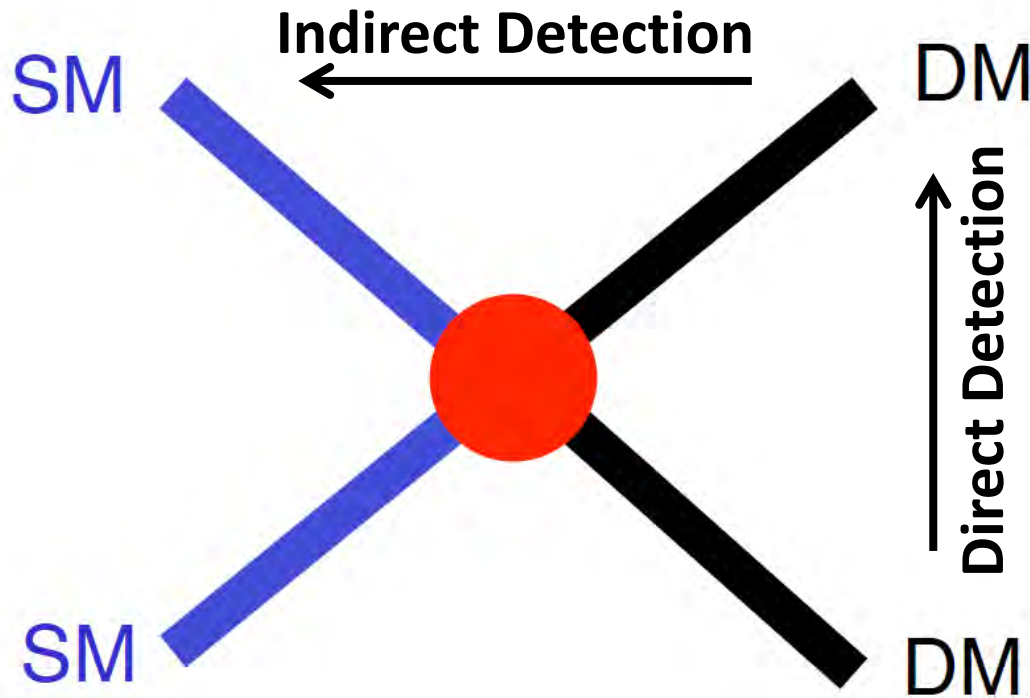

Scattering of DM particles on nuclei of detector material; detect recoil.
For a given cross section sensitivity scales with detector size.

Detecting Dark Matter

Assume annihilation of DM particles, e.g. in the sun. Detect annihilation products.

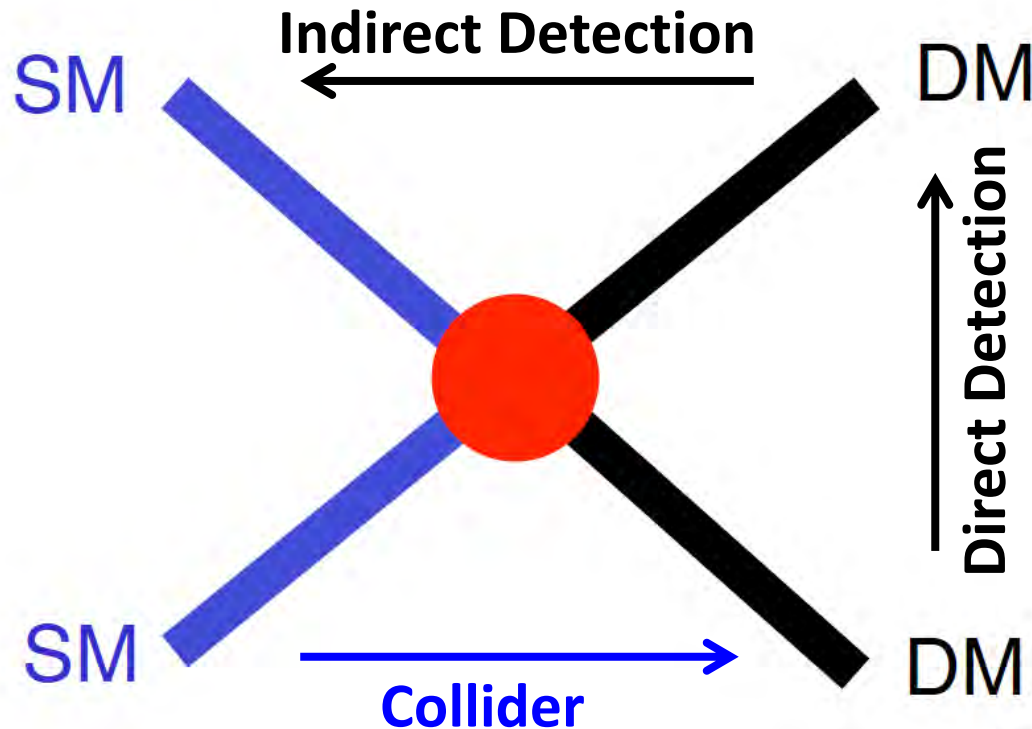

Scattering of DM particles on nuclei of detector material; detect recoil.
For a given cross section sensitivity scales with detector size.

DM may be pair produced in pp collisions at the LHC, with masses $< \frac{1}{2}$ parton-parton c.o.m. Yields experimental signature of MET.



Direct scattering experiments

Indirect detection experiments

Pair-production at the LHC

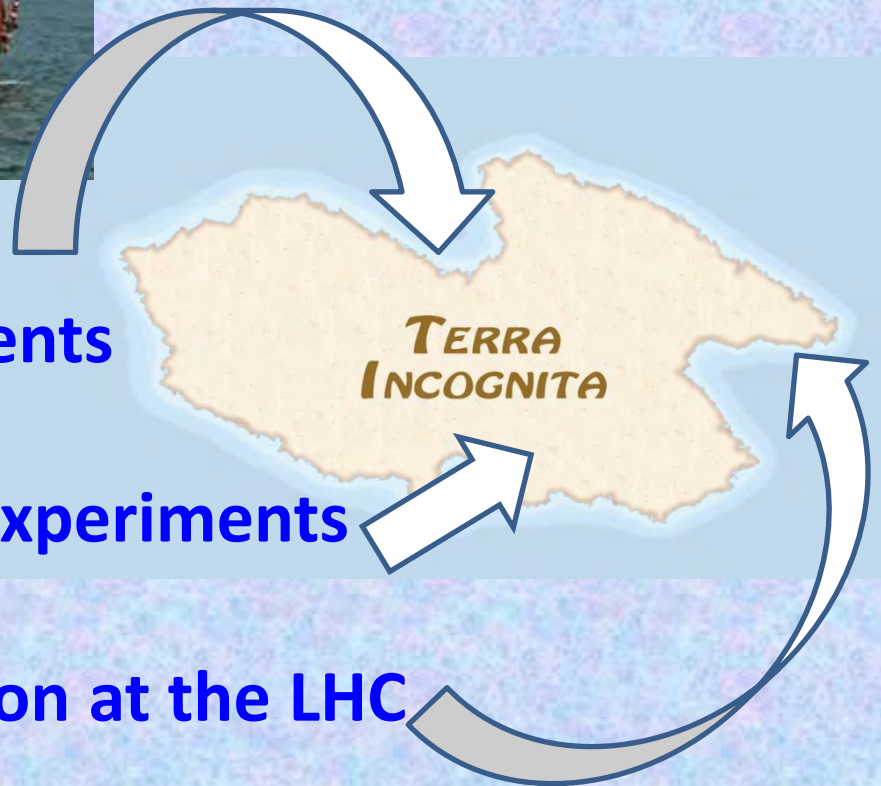

The Large Hadron Collider (LHC)

Two General-Purpose Experiments:

CMS & ATLAS

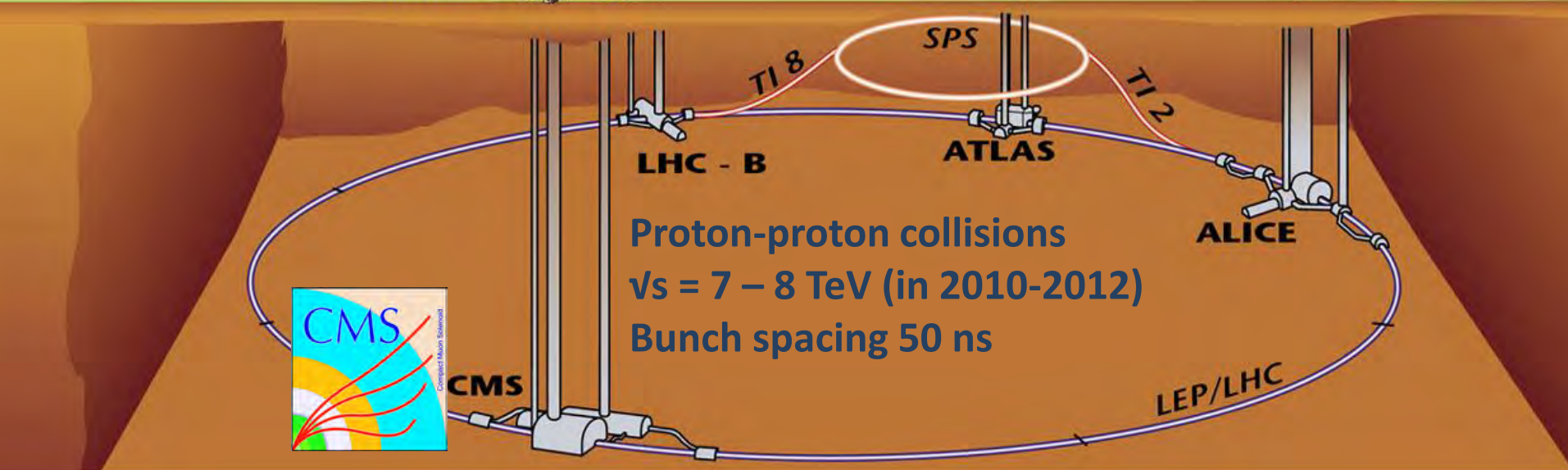
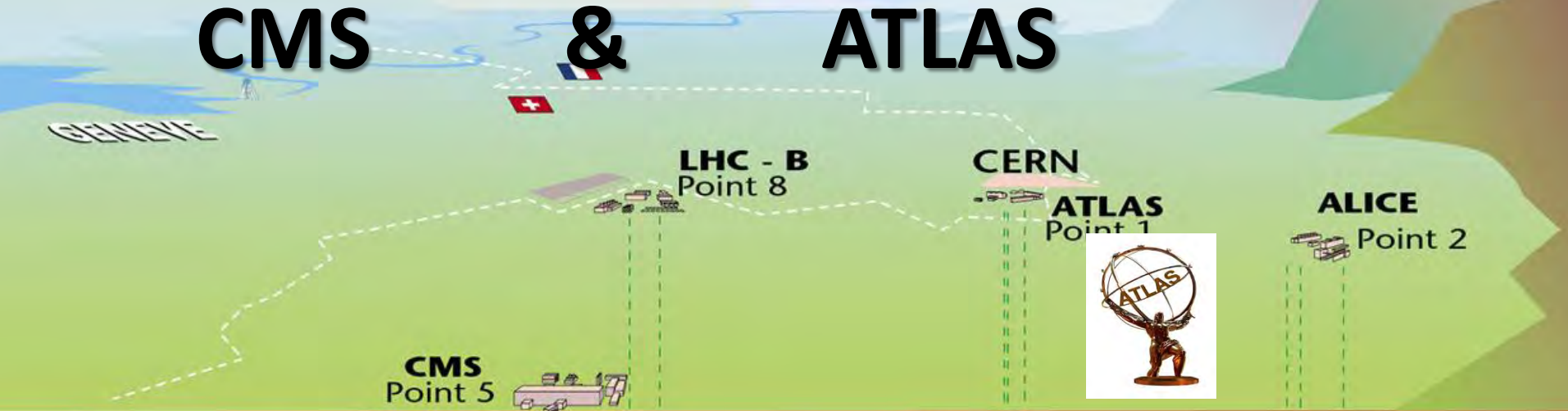



ATLAS

[ATLAS coll.: JINST 3, S08003 (2008)]

Excellent stand-alone muon measurement. Emphasis on jet and missing- E_T (MET) resolution, particle identification

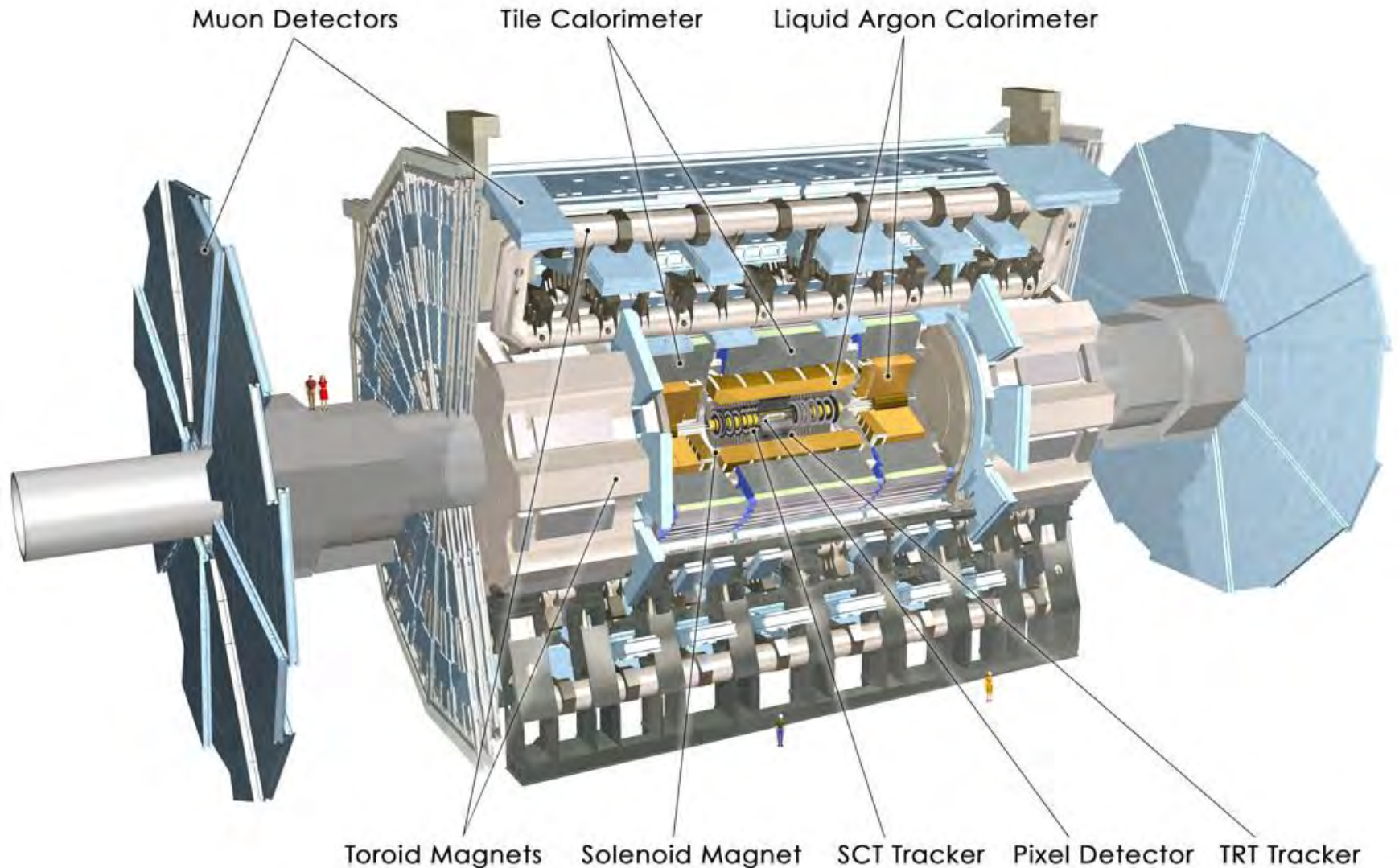



Compact Muon Solenoid (CMS)

[CMS coll.:
JINST 3 (2008), no. S08004]

Emphasis on electron and photon energy measurement,
full silicon tracker providing high momentum resolution

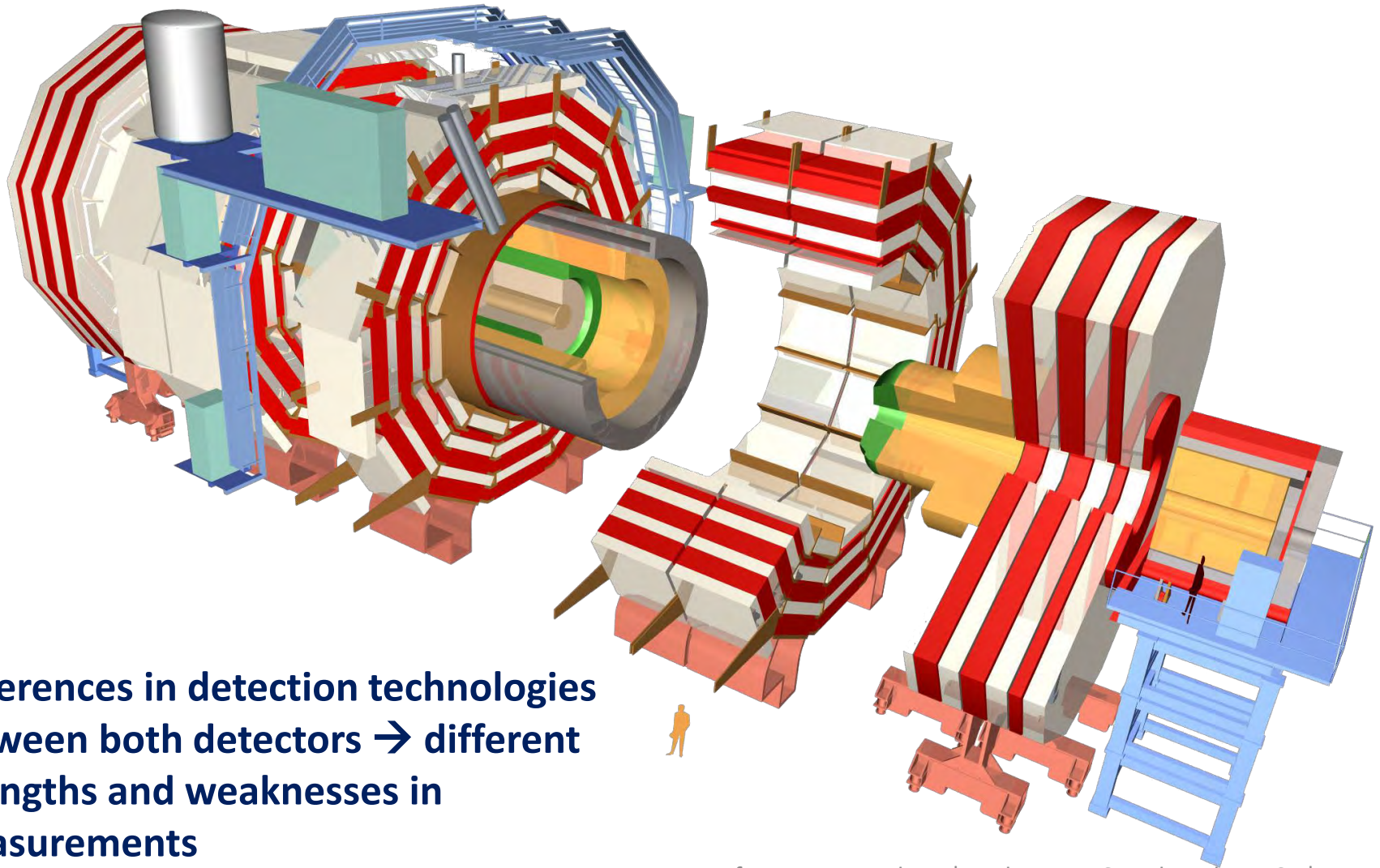

Differences in detection technologies
between both detectors → different
strengths and weaknesses in
measurements

LHC Data Taking

Recorded luminosity of high quality data $\sim 25 \text{ fb}^{-1}$

\sqrt{s} (LHC) = 4 x \sqrt{s} (Tevatron)

Data taking efficiency >90% for ATLAS and CMS

$$\mathcal{L} = f \cdot k^2 \cdot \frac{n^2}{A}$$

f=frequency
k=number of bunches
n=particles/bunch
A=beam cross section

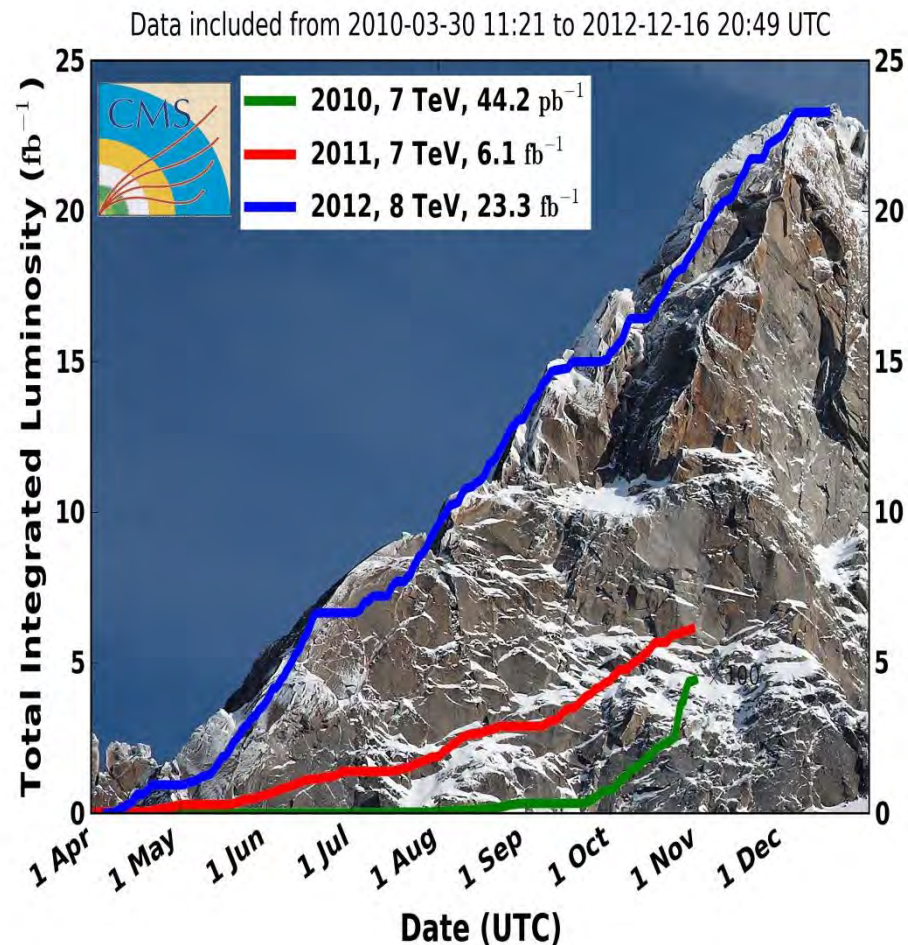

Many Searches Performed at the LHC to address open questions of SM



Final states allow different interpretations
Be ready also for the unexpected

Searches guided by **specific models** trying to address open questions \rightarrow beyond Higgs-boson **no** further new particles or phenomena yet

ATLAS Exotics Searches* - 95% CL Lower Limits (Status: May 2013)

Search Category	Search Description	Lower Limit [TeV]	Model / Phenomenon
Extra dimensions	Large ED (ADD) : monojet + $E_{T,miss}$	4.37 TeV	$M_D (\delta=2)$
	Large ED (ADD) : monophoton + $E_{T,miss}$	1.93 TeV	$M_D (\delta=2)$
	Large ED (ADD) : diphoton + dilepton, $m_{\gamma\gamma/l\bar{l}}$	4.18 TeV	$M_S (HLZ \delta=3, NLO)$
	UED : diphoton + $E_{T,miss}$	1.40 TeV	Compact scale R^{-1}
	S/Z, ED : dilepton, m_{ll}	4.71 TeV	$M_{KK} - R^{-1}$
	RS1 : dilepton, m_{ll}	2.47 TeV	Graviton mass ($k/M_{Pl} = 0.1$)
	RS1 : WW resonance, m_{ll}	1.23 TeV	Graviton mass ($k/M_{Pl} = 0.1$)
	Bulk RS : ZZ resonance, m_{ll}	850 GeV	Graviton mass ($k/M_{Pl} = 1.0$)
	RS $g \rightarrow \bar{t}t$ (BR=0.925) : $\bar{t}t \rightarrow l^+l^-$ jets, m_{ll}	2.07 TeV	g_{KK} mass
	ADD BH ($M_{Th}/M_{Pl} = 3$) : SS dimuon, $N_{eff,part}$	1.25 TeV	$M_D (\delta=6)$
CI	ADD BH ($M_{Th}/M_{Pl} = 3$) : leptons + jets, $L\bar{P}$	1.5 TeV	$M_D (\delta=6)$
	Quantum black hole : dijet, $F(m_s)$	4.11 TeV	$M_D (\delta=6)$
	qqqq contact interaction : $\chi(m_s)$	7.6 TeV	Λ
	qqll CI : ee + $\mu\mu$, m_{ll}	13.9 TeV	Λ (constructive int.)
	uutt CI : SS dilepton + jets + $E_{T,miss}$	3.3 TeV	Λ (C=1)
	Z' (SSM) : m_{ll}	2.86 TeV	Z' mass
	Z' (SSM) : m_{ll}	1.4 TeV	Z' mass
	Z' (leptophobic topcolor) : $\bar{t}t \rightarrow l^+l^-$ jets, m_{ll}	1.8 TeV	Z' mass
	W' (SSM) : m_{ll}	2.55 TeV	W' mass
	W' ($\rightarrow tq, g=1$) : m_{ll}	430 GeV	W' mass
LQ	W' ($\rightarrow tb, LRSM$) : m_{ll}	1.84 TeV	W' mass
	Scalar LQ pair ($\beta=1$) : kin. vars. in eejj, evisj	660 GeV	1 st gen. LQ mass
	Scalar LQ pair ($\beta=1$) : kin. vars. in $\mu\mu jj, \mu\mu visj$	685 GeV	2 nd gen. LQ mass
	Scalar LQ pair ($\beta=1$) : kin. vars. in $\tau\tau jj, \tau\tau visj$	534 GeV	3 rd gen. LQ mass
	4 th generation : $l^+l^- \rightarrow WbWb$	656 GeV	l' mass
	4 th generation : $b^+b^- \rightarrow SS$ dilepton + jets + $E_{T,miss}$	720 GeV	b' mass
	Vector-like quark : $TT \rightarrow H^+X$	790 GeV	T mass (isospin doublet)
	Vector-like quark : CC, m_{ll}	1.12 TeV	VLO mass (charge -1/3, coupling $\kappa_{q0} = v/m_{q0}$)
	Excited quarks : γ -jet resonance, m_{ll}	2.46 TeV	q' mass
	Excited quarks : dijet resonance, m_{ll}	3.84 TeV	q' mass
Other	Excited quarks : W-t resonance, m_{ll}	870 GeV	b' mass (left-handed coupling)
	Excited leptons : γ -jet resonance, m_{ll}	2.2 TeV	l' mass ($\Lambda = m(l'')$)
	Techni-hadrons (LSTC) : dilepton, m_{ll}	850 GeV	ρ/a_s mass ($m(\rho/a_s) - m(\tau_s) = M_{\rho}$)
	Techni-hadrons (LSTC) : WZ resonance (ll), m_{ll}	920 GeV	ρ_s mass ($m(\rho_s) = m(\tau_s) + m_{W, a_0} = 1.1m(\rho_s)$)
	Major. neutr. (LRSM, no mixing) : $2l\text{-lep} + \text{jets}$	1.8 TeV	N mass ($m(W) = 2 \text{ TeV}$)
	Heavy lepton N' (type III seesaw) : Z-l resonance, m_{ll}	1.2 TeV	N' mass ($ V_{lN} = 0.055, V_{lN} = 0.063, V_{lN} \neq 0$)
	H_c^+ (DY prod., BR($H_c^+ \rightarrow ll$)=1) : SS ee ($\mu\mu$), m_{ll}	409 GeV	H_c^+ mass (limit at 398 GeV for $\mu\mu$)
	Color octet scalar : dijet resonance, m_{ll}	1.95 TeV	Scalar resonance mass
	Multi-charged particles (DY prod.) : highly ionizing tracks	490 GeV	mass ($ q = 4e$)
	Magnetic monopoles (DY prod.) : highly ionizing tracks	86 GeV	mass

*Only a selection of the available mass limits on new states or phenomena shown



Searches guided by **specific models** trying to address open questions \rightarrow beyond Higgs-boson **no further new particles or phenomena yet**

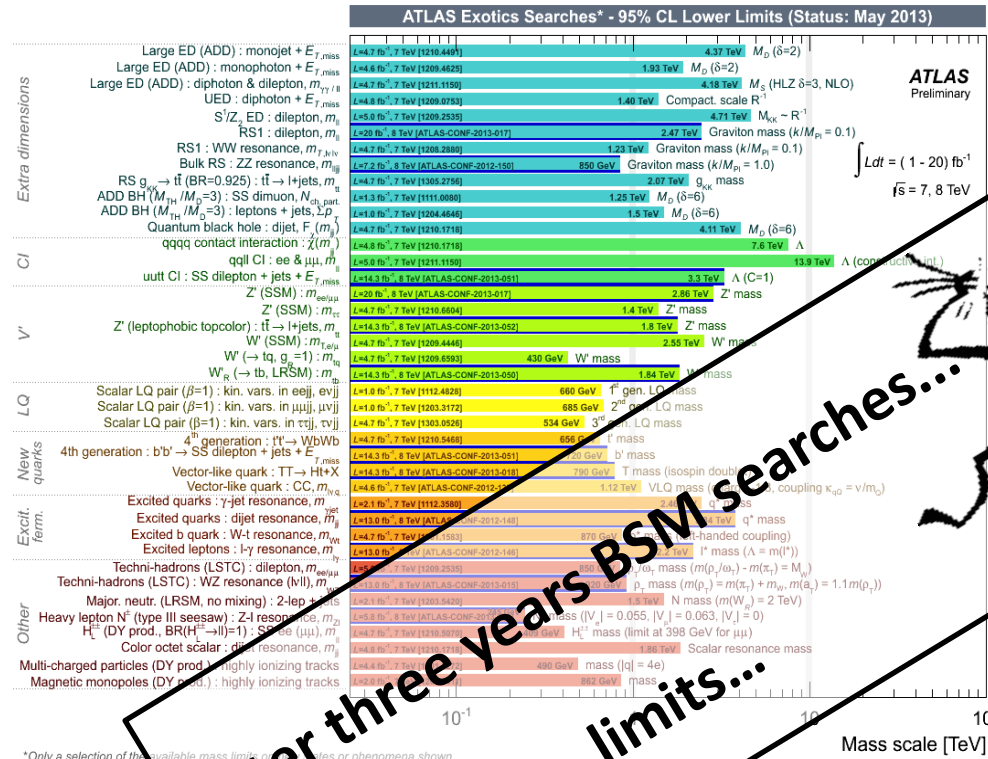

After three years BSM searches... Limits, limits, limits...

Can we learn something about dark matter?

Dark Matter at the LHC

pp collisions

Pair of DM particles

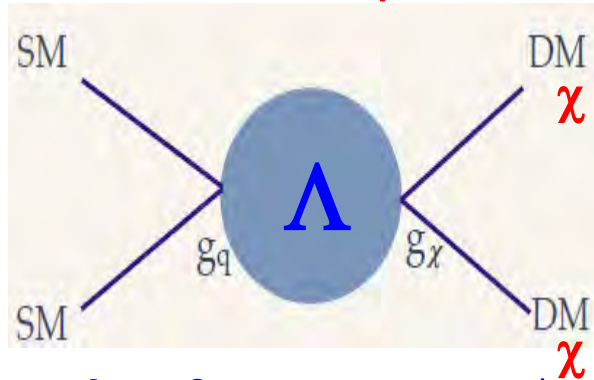

Scale of interaction Λ

New physics expressed with a **contact interaction** between DM and SM particles.

Use **effective field theory (EFT)** to describe interactions in a model independent way.

➔ Signature oriented search

Dark matter at the LHC

pp collisions

Pair of DM particles

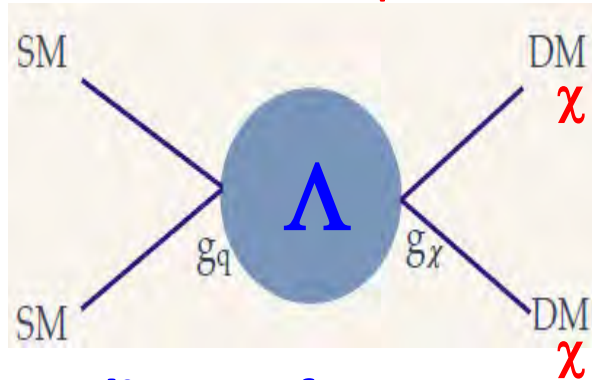

Mediator of mass M

Cross section depends on the mass (m_χ) and scale Λ (for couplings g_χ, g_q)

Spin-independent (SI) and spin-dependent (SD) cross sections

Characterizing parameters:

- scale of effective interaction

$$\Lambda = M / \sqrt{g_\chi g_q}$$

- mass m_χ

[Bai, Fox and Harnik, JHEP 1012:048 (2010)]

[Goodman, Ibe, Rajaraman, Shepherd, Tait, Yu, Phys.Rev.D82:116010 (2010)]

$$\sigma_{SI} = 9 \frac{\mu^2}{\pi \Lambda^4}$$
$$\sigma_{SD} = 0.33 \frac{\mu^2}{\pi \Lambda^4}$$

$$\mu = \frac{m_\chi m_p}{m_\chi + m_p}$$

Possible Couplings

Pair production of χ can be characterized by a contact interaction with **most prominent couplings**

Vector coupling (**V**) D5

→ Spin-**in**dependent (SI)

$$\mathcal{O}_V = \frac{(\bar{\chi}\gamma_\mu\chi)(\bar{q}\gamma^\mu q)}{\Lambda^2}$$

Axial-vector coupling (**AV**) D8

→ Spin-**de**pendent (SD)

$$\mathcal{O}_{AV} = \frac{(\bar{\chi}\gamma_\mu\gamma_5\chi)(\bar{q}\gamma^\mu\gamma_5q)}{\Lambda^2}$$

Also studied:

scalar D1, D11 (ATLAS mono-jet/photon) → SI

tensor D9 (ATLAS mono-photon) → SD

Run / Event: 139779 / 4994190

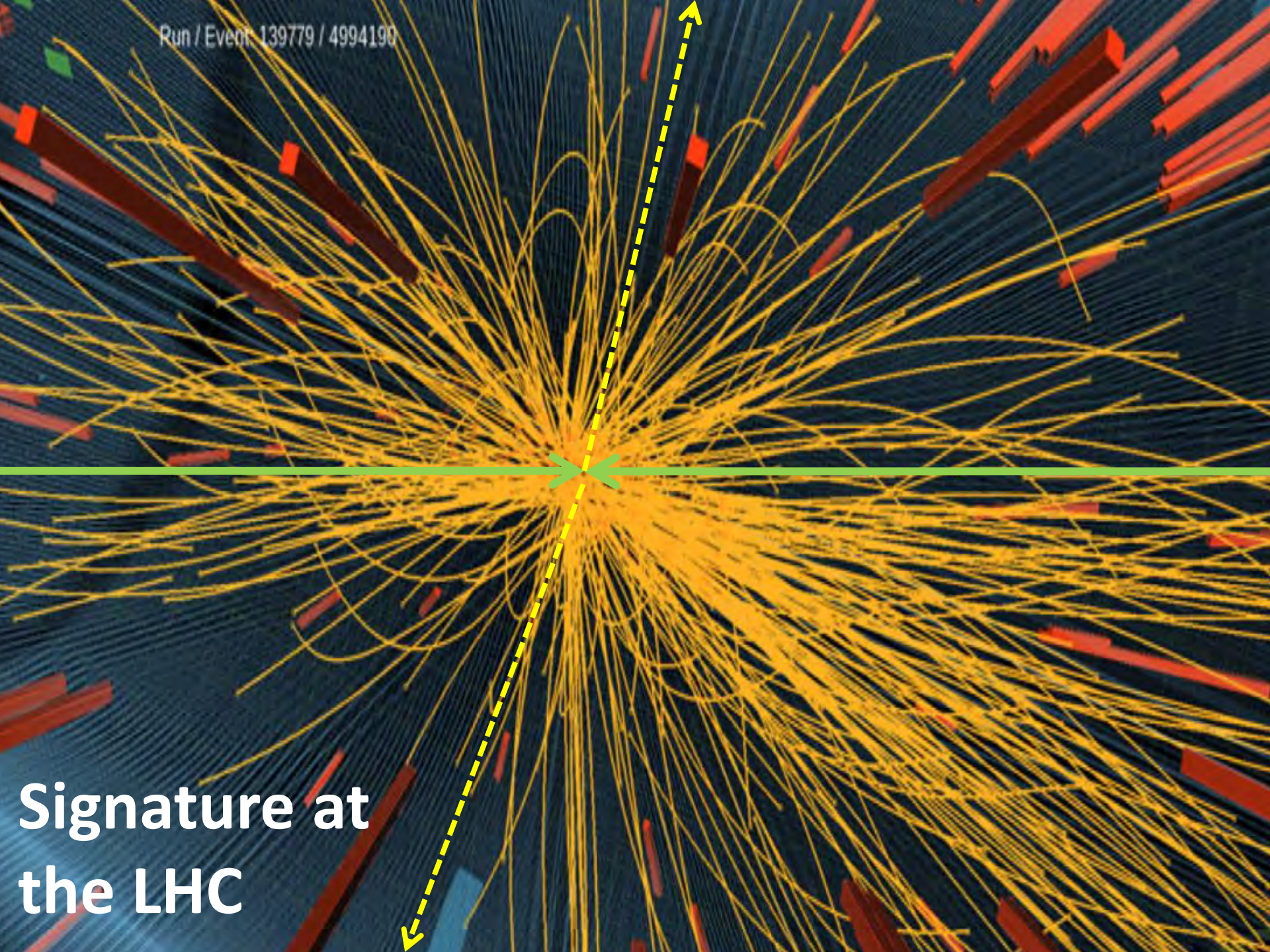

Signature at
the LHC

How to make DM visible at the LHC?

Mono-X Signatures – simple and striking

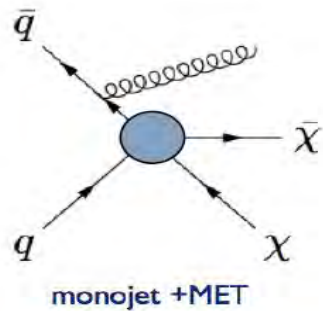

Radiation of a jet / photon from initial state

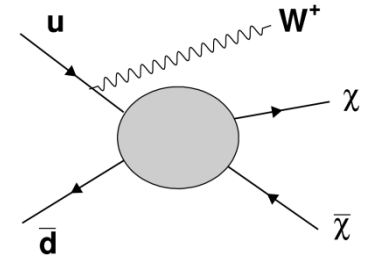
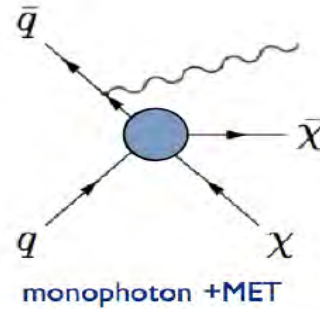

Different W/Z decay channels

[CMS-PAS-EXO-12-048](#)

Full 2012 dataset 20/fb

[ATLAS-CONF-12-147 \(JHEP 04 \(2013\) 075\)](#)

Full 2011 dataset 5/fb

[CMS-PAS-EXO-11-096](#)

[\(PRL 108, 261803 \(2013\)\)](#)

[ATLAS PRL 110, 011802 \(2013\)](#)

Full 2011 dataset 5/fb

[CMS-PAS-EXO-13-004](#)

[ATLAS-CONF-13-073 \(PRL 112 \(041802\)\)](#)

Full 2012 dataset 20/fb

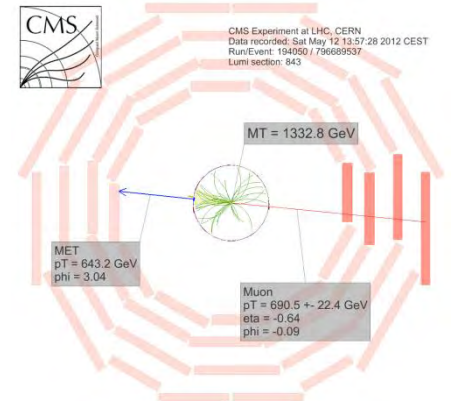
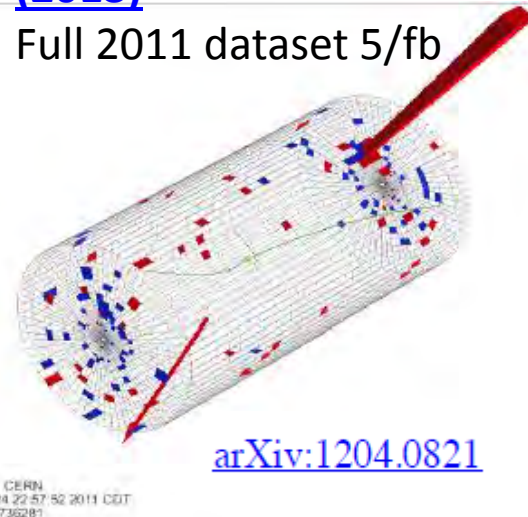
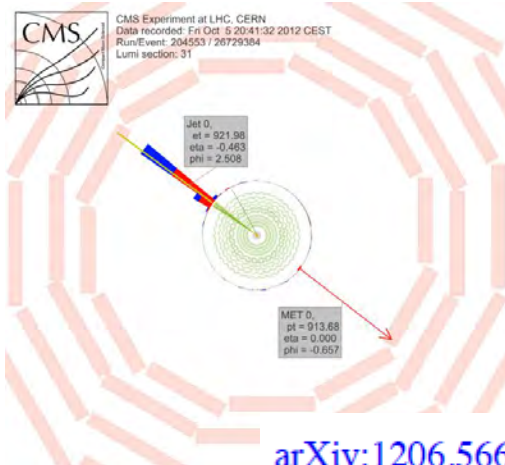

Search for Pair Produced Dark Matter in **Monojet** Channel

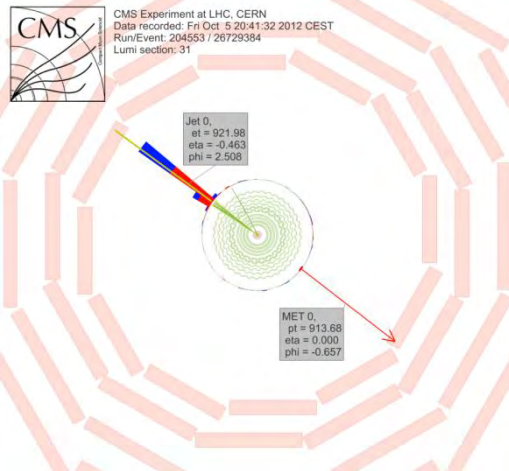
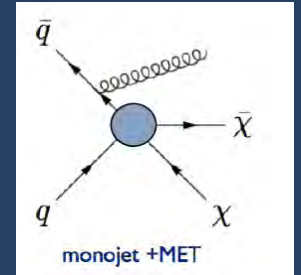

Signature: high p_T jet + MET

CMS-PAS-EXO-12-048 (20/fb)
ATLAS-CONF-12-147 (10.5/fb)
2012 pp data at $\sqrt{s} = 8$ TeV

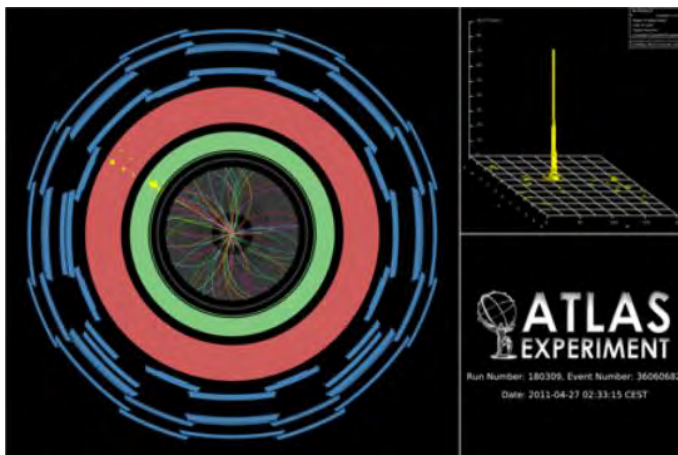

Channel to start DM searches at colliders
2012 results

Event Selection

CMS-PAS-EXO-12-048 (20/fb) ATLAS-CONF-2012-147 (10.5/fb)

Search for single jet recoiling against MET

- Good primary vertex
- Large missing E_T
 - MET(CMS) > 250 GeV
 - MET(ATLAS) > 120 GeV
- Anti-kT jet with $R=0.4$ within $|\eta| < 2.0$
 - p_T (CMS) > 110 GeV
 - p_T (ATLAS) > 120 GeV
- Allow for second jet with $p_T > 30$ GeV if $\Delta\phi(j1, j2) < 2.5$ or $\Delta\phi(\text{MET}, j2) > 0.5$
- Jet quality
- Lepton veto

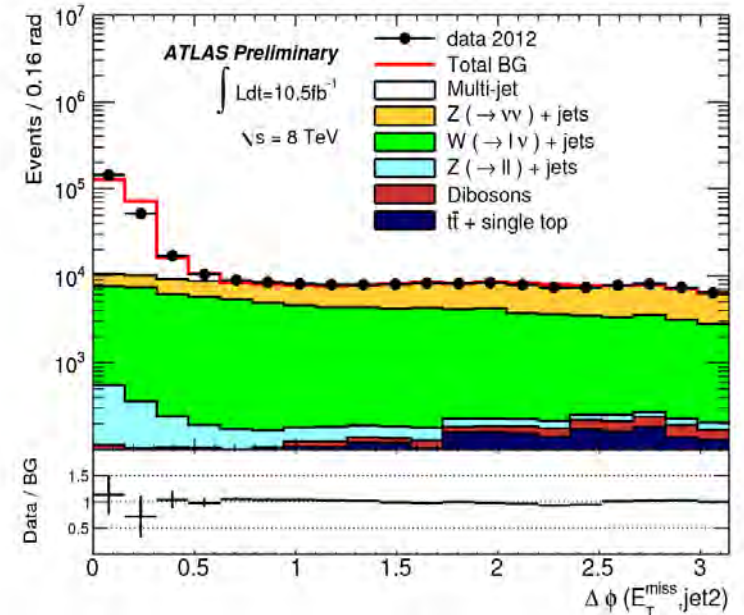
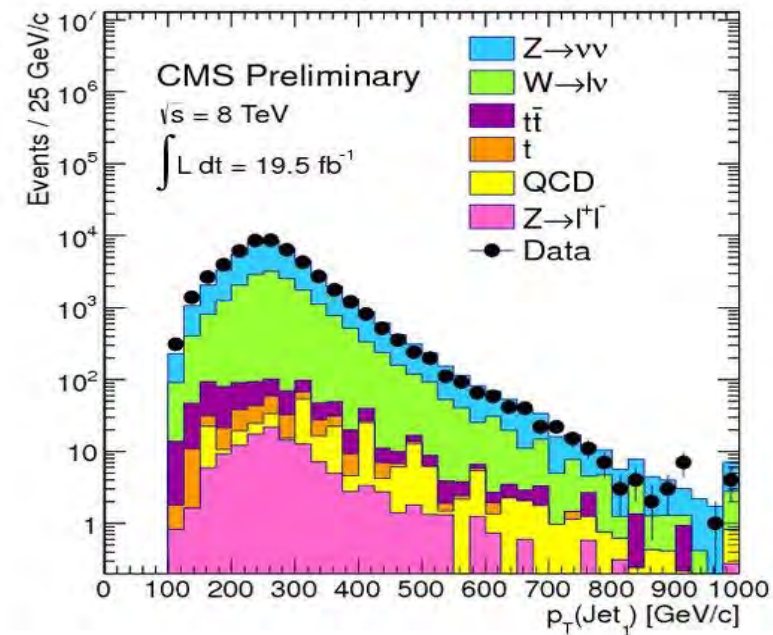

Signal

DM is undetectable \rightarrow MET
Jet to balance p in transverse plane
 \rightarrow high p_T object

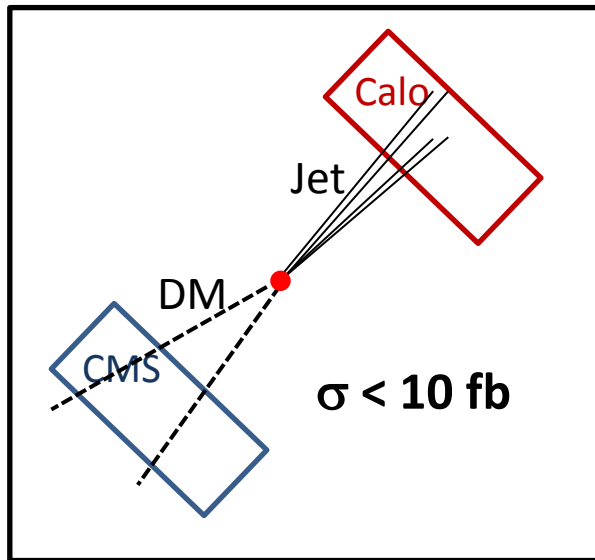
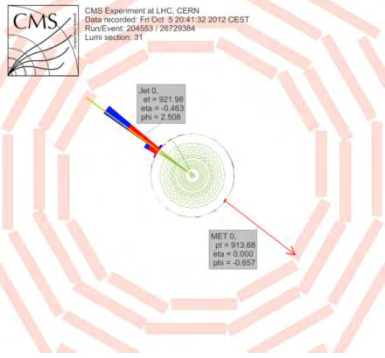

Signal and Background

DM is undetectable \rightarrow MET
Jet to balance p in transverse plane
 \rightarrow high p_T object

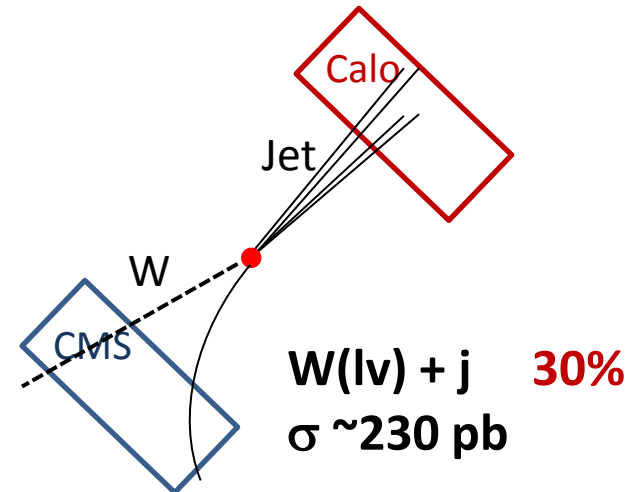
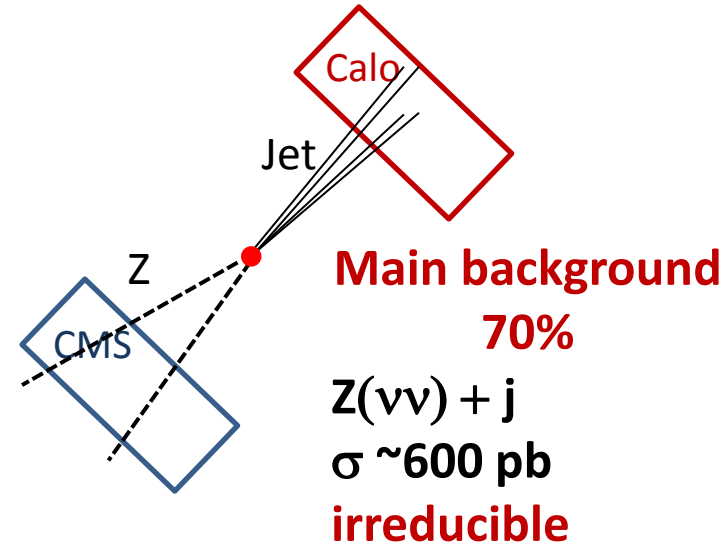
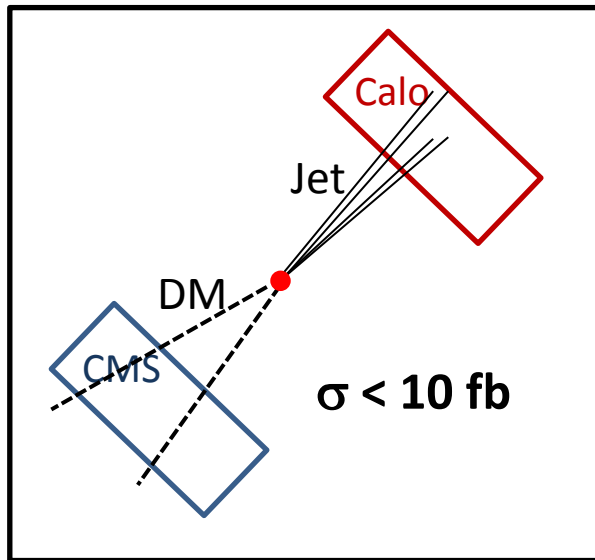
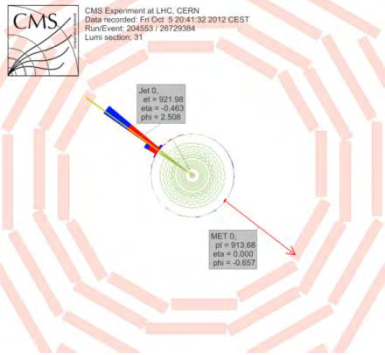

Signal and Background

DM is undetectable \rightarrow MET
Jet to balance p in transverse plane
 \rightarrow high p_T object

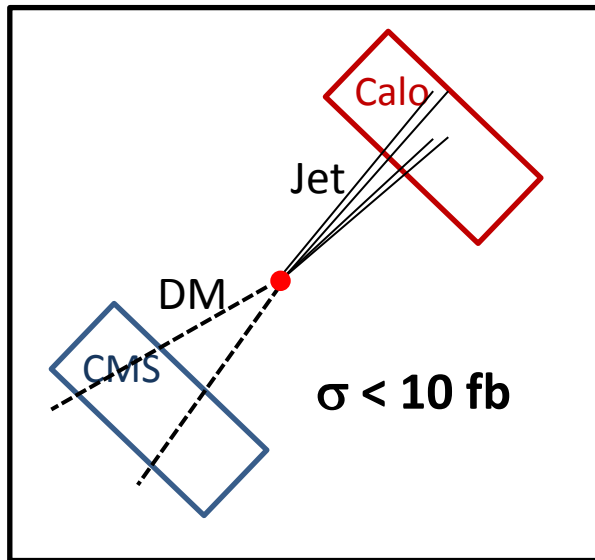
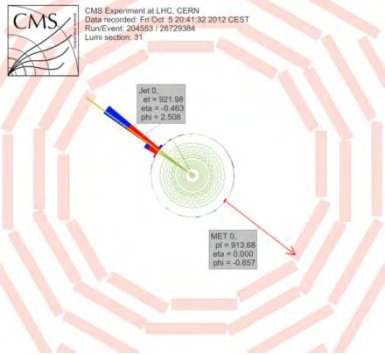

Data driven from
 $Z(\mu\mu) + j$

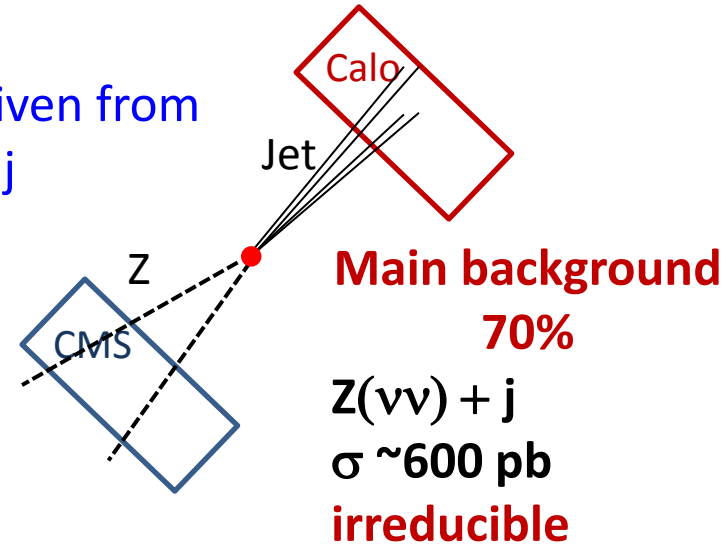

Data driven from
 $W(\mu\nu) + j$

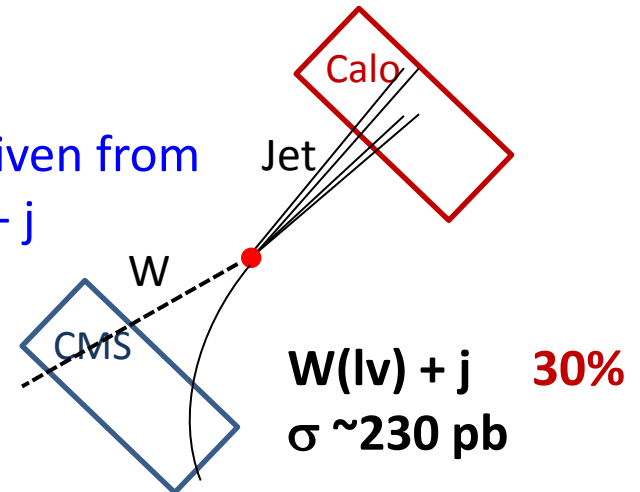

Signal and Background

CMS-PAS-EXO-12-048 (20/fb)

Dominant background $Z \rightarrow \nu\nu + j$
 data driven from $Z \rightarrow \mu\mu + j$

$$N(Z(\nu\nu)) = \frac{N^{\text{obs}} - N^{\text{bgd}}}{A \times \epsilon} \cdot R \left(\frac{Z(\nu\nu)}{Z(\mu\mu)} \right)$$

Table 3: Data-driven prediction of $Z(\nu\nu)$ events for different E_T^{miss} regions.

E_T^{miss} (GeV)	> 250	> 300	> 350	> 400	> 450	> 500	> 550
$Z(\nu\nu)$	30600 ± 1493	12119 ± 640	5286 ± 323	2569 ± 188	1394 ± 127	671 ± 81	370 ± 58

Syst. Uncertainties 5 → 15% (dominated by statistics, selection efficiency)

Possible signal and backgrounds in MET distribution after all cuts

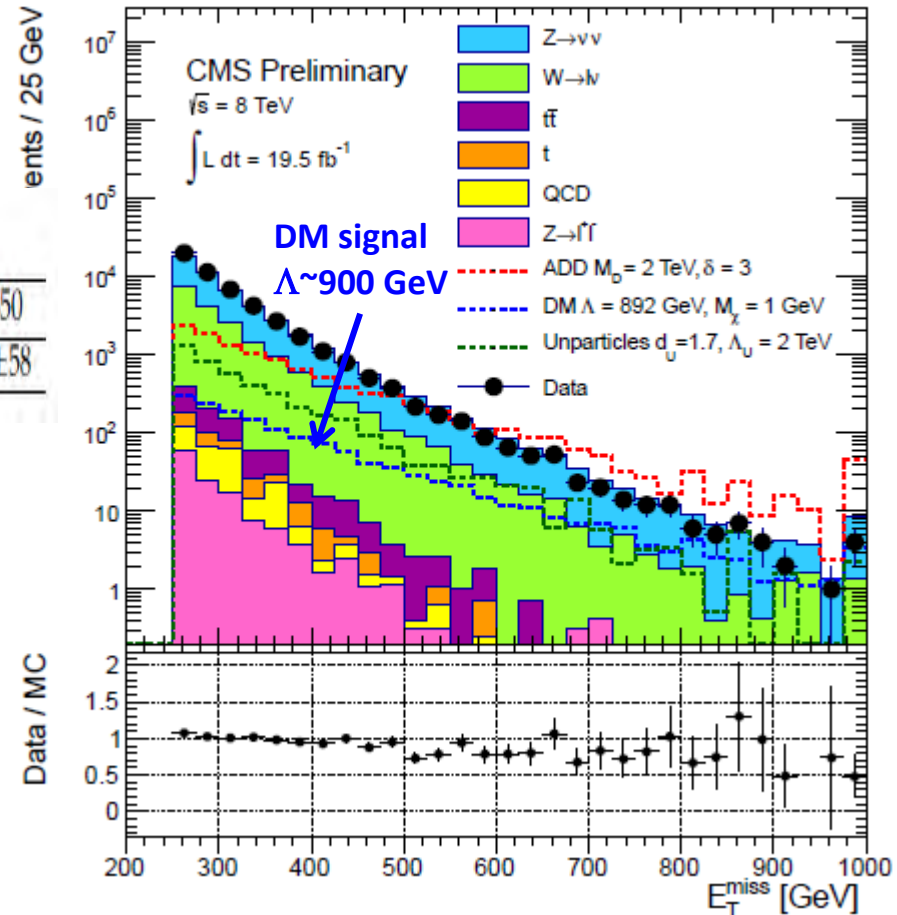

CMS search performed in 7 bins of MET

Signal and Background

CMS-PAS-EXO-12-048 (20/fb)

Dominant background $Z \rightarrow \nu\nu + j$
 data driven from $Z \rightarrow \mu\mu + j$

$$N(Z(\nu\nu)) = \frac{N^{\text{obs}} - N^{\text{bgd}}}{A \times \epsilon} \cdot R \left(\frac{Z(\nu\nu)}{Z(\mu\mu)} \right)$$

- **W+jets** (~30%) data driven
- **QCD** : rejected by $\Delta\phi$ cut
- **EWK** : veto events with isolated tracks and isolated leptons
- **Other** backgrounds are negligible (~1%), taken from MC

Possible signal and backgrounds in **MET** distribution after all cuts

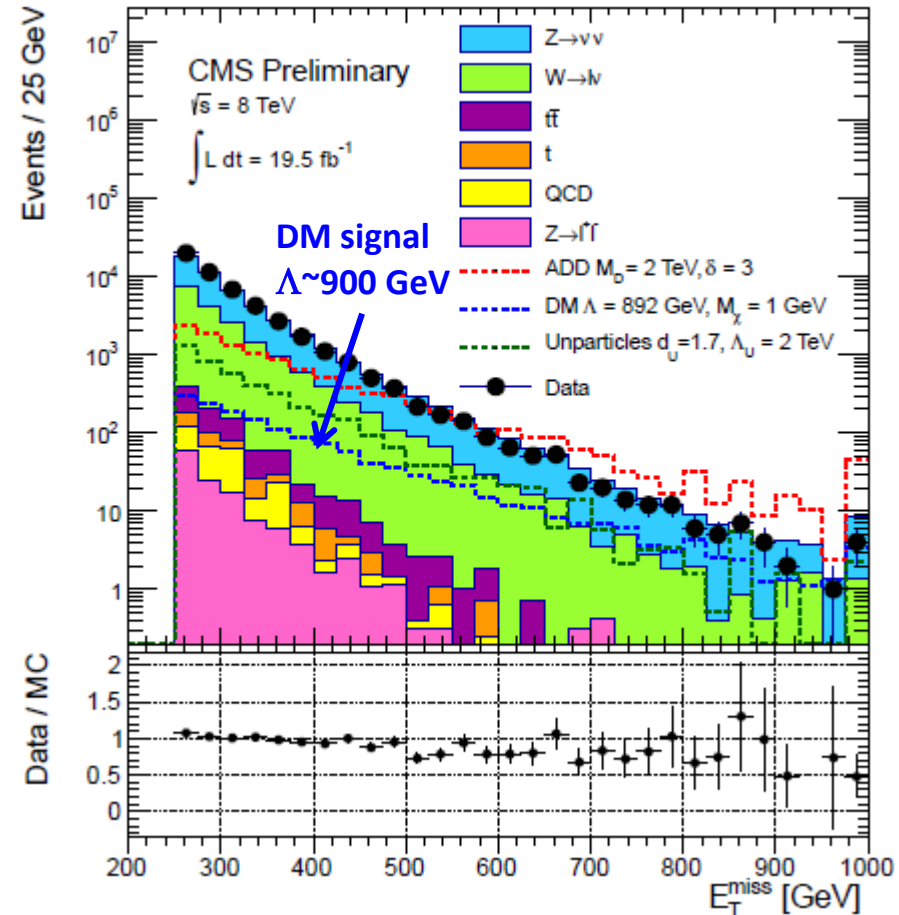

CMS search performed in 7 bins of MET

Monojet Model Independent Limits

ATLAS-CONF-2012-147 (10.5/fb) CMS-PAS-EXO-12-048 (20/fb)

→ Search performed in bins of MET

Both experiments quote model-independent limits

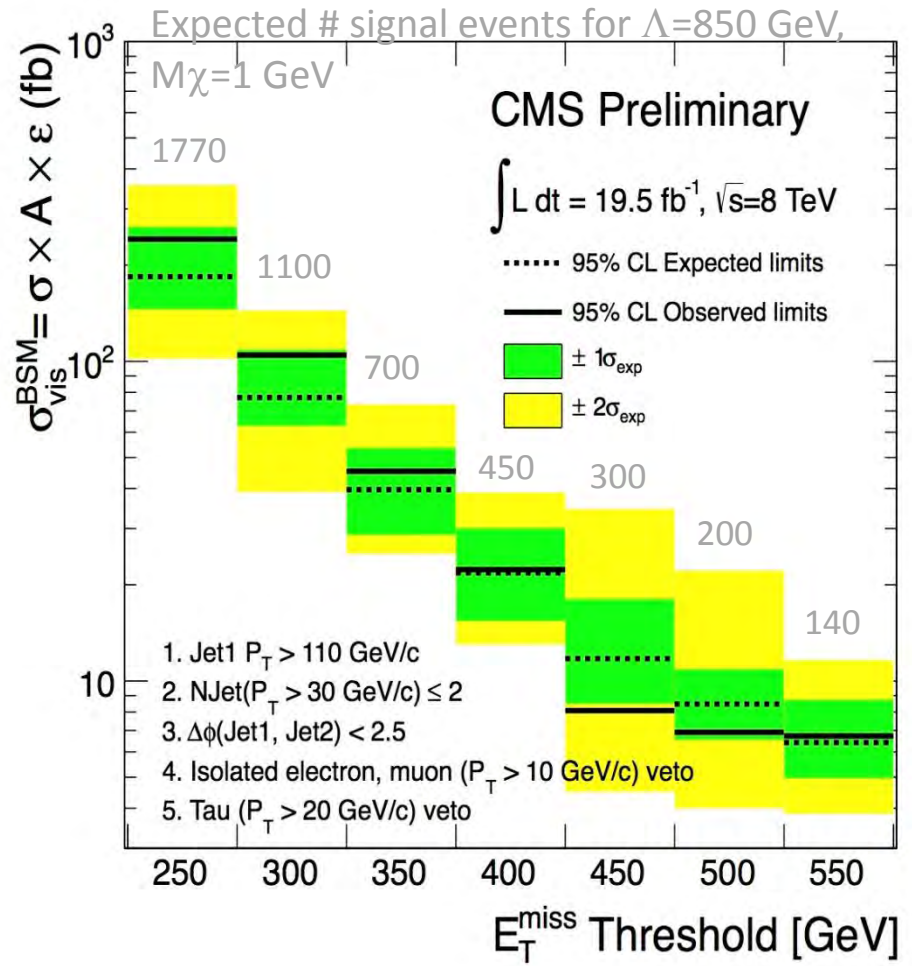
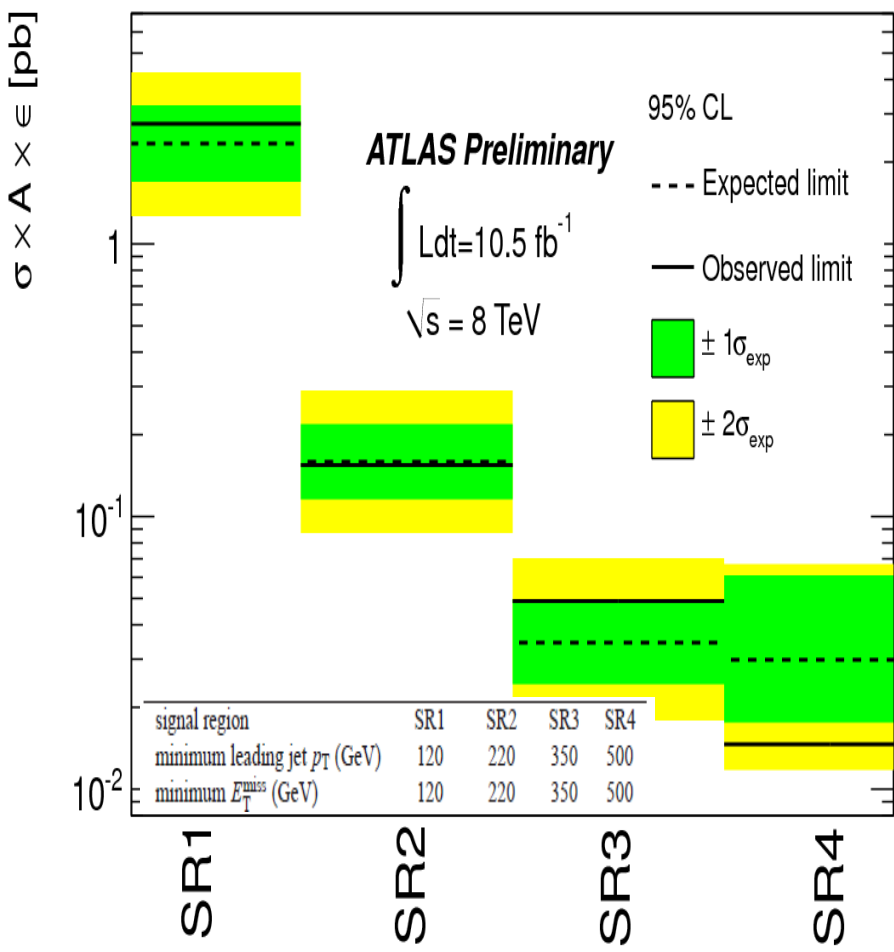

Translate production cross section limit into DM – nucleon limits

Purpose: to compare to direct detection experiments

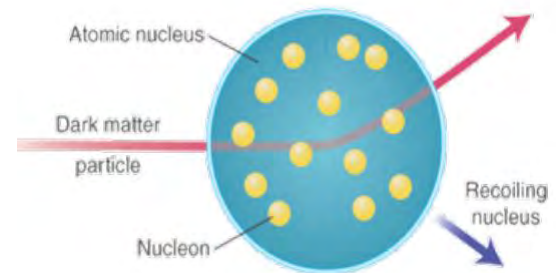
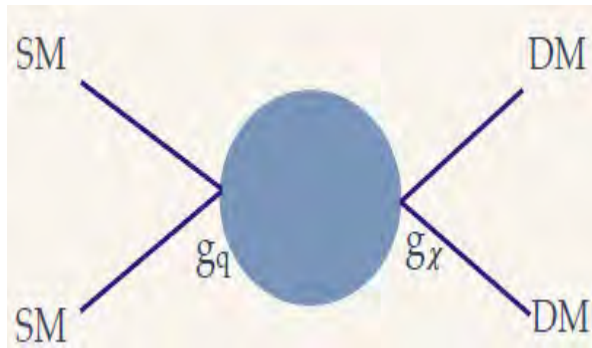

EFT to translate limits to same plane as direct detection experiments

Experimental result

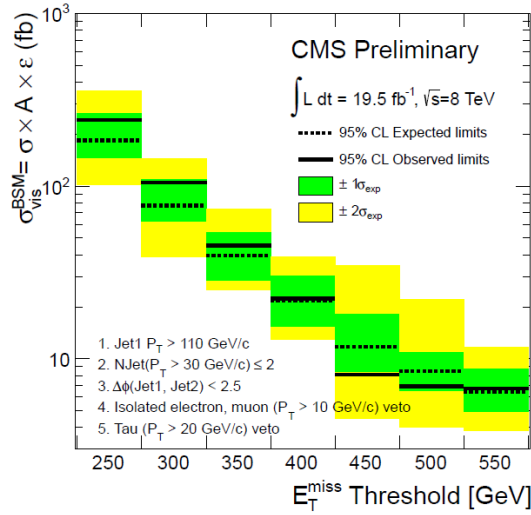

Convert pp xsec limit into Λ

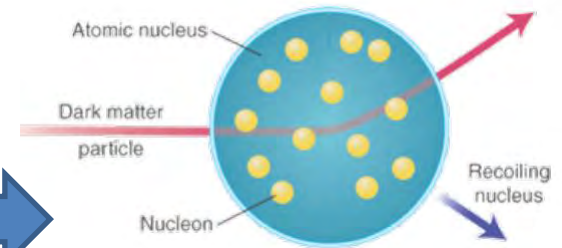
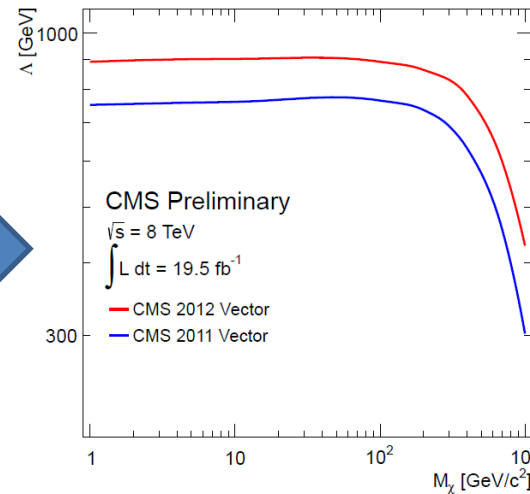

Spin-Independent

$$\mathcal{O}_{-N}^N = f_q^N \frac{(\bar{N} \gamma^\mu N) (\bar{\chi} \gamma_\mu \chi)}{\Lambda^2}$$

Coefficient relating nucleon and quark operator

Vector operator

$$\frac{1}{\Lambda^2} \bar{\chi} \gamma^\mu \chi \quad \xi_i \bar{q}_i \gamma_\mu q_i$$

μ = reduced mass of the nucleon (p or n) system

with $f_u^p = f_d^n = 2, f_d^p = f_u^n = 1$
 $f = 0$ for other quarks

$$\sigma_{SI} = \frac{\mu^2}{\pi \Lambda^4} \left(\sum_q f_q^N \right)^2$$

arXiv:0803.2360.

EFT to translate limits to same plane as direct detection experiments

Experimental result

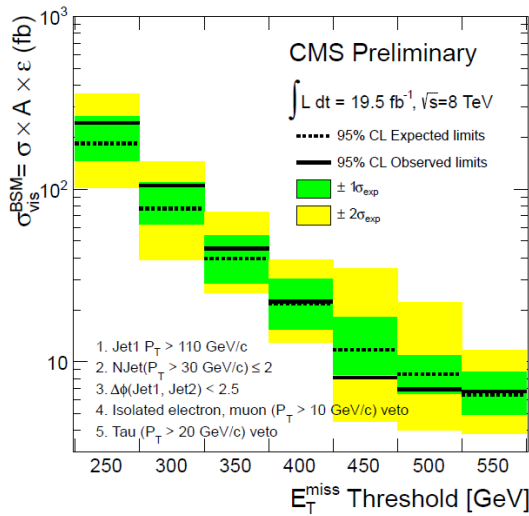

Axial-Vector operator

$$\frac{1}{\Lambda^2} \bar{\chi} \gamma^\mu \gamma^5 \chi \quad \bar{\xi}_i \bar{q}_i \gamma_\mu \gamma^5 q_i$$

Convert pp xsec limit into Λ

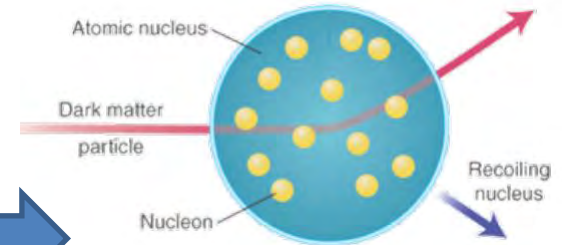
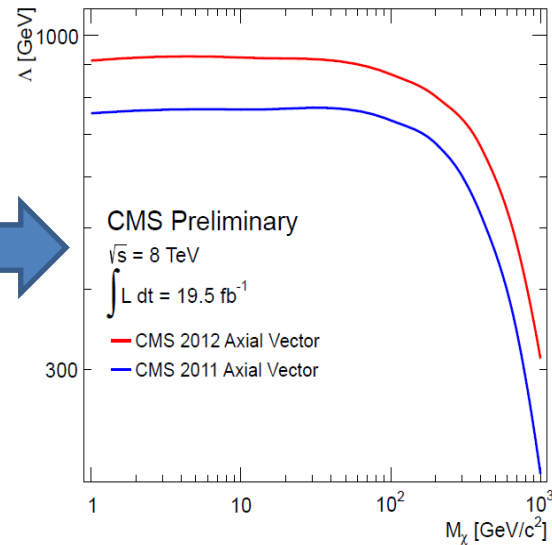

Spin-Dependent

$$\mathcal{O}^{Nq} = \Delta_q^N \frac{(N \gamma^\mu \gamma^5 N) (\bar{\chi} \gamma_\mu \gamma^5 \chi)}{\Lambda^2}$$

Sum of quark helicities

μ = reduced mass of the nucleon (p or n) system

$$\Delta_u^p = \Delta_d^n = 0.842 \pm 0.012$$

$$\Delta_d^p = \Delta_u^n = -0.427 \pm 0.013$$

$$\Delta_s^p = \Delta_s^n = -0.085 \pm 0.018$$

arXiv:0803.2360.

$$\sigma_{SI} = \frac{3\mu^2}{\pi \Lambda^4} \left(\sum_q \Delta_q^N \right)^2$$

DM – Nucleon Limits

ATLAS and CMS results similar for 7 TeV data, improved with 8 TeV

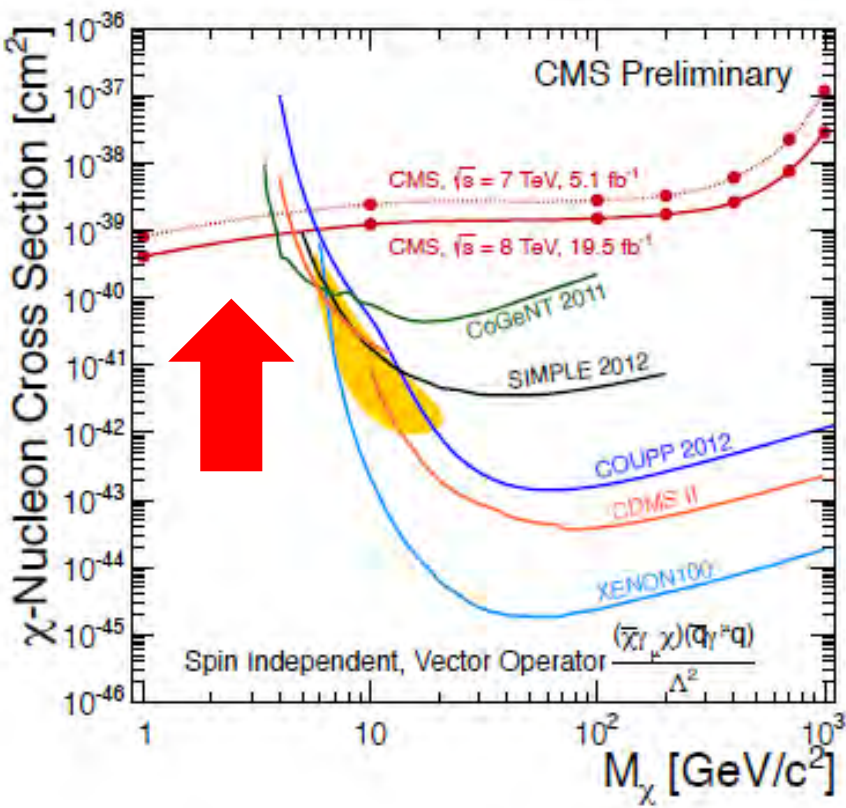

LHC can access very low DM masses

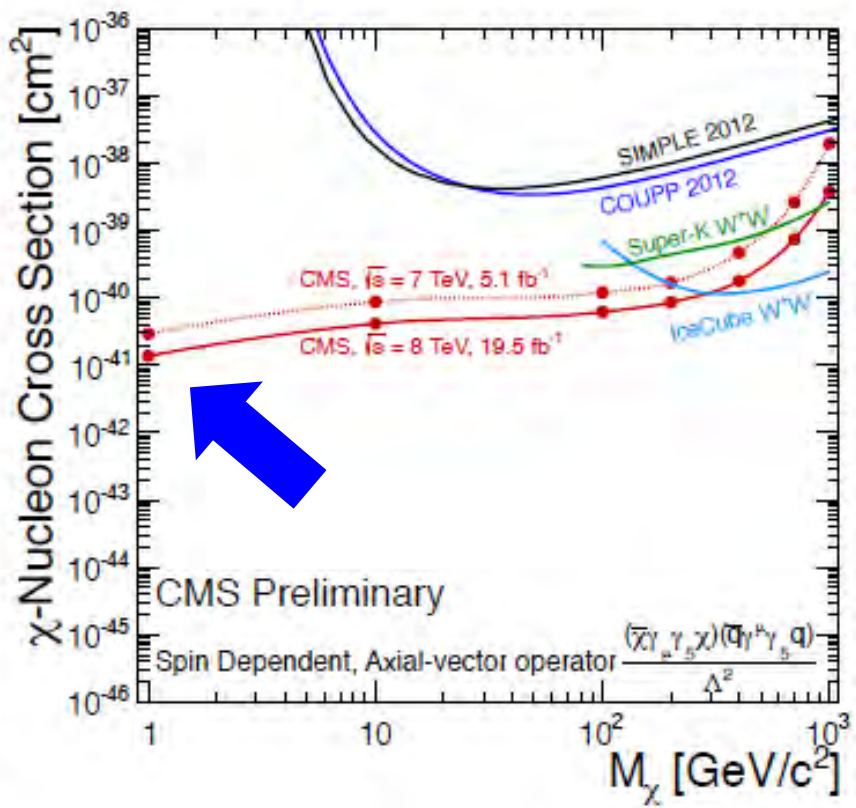

Exclude large cross sections for spin-dependent case

Search for Pair Produced Dark Matter in **Monophoton** Channel

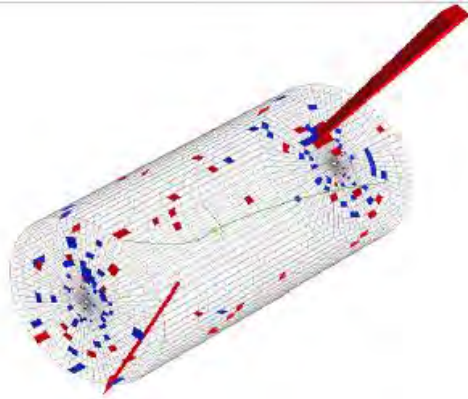
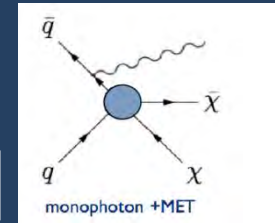

CERN
24.22.57.52 2011 CDT
1736281

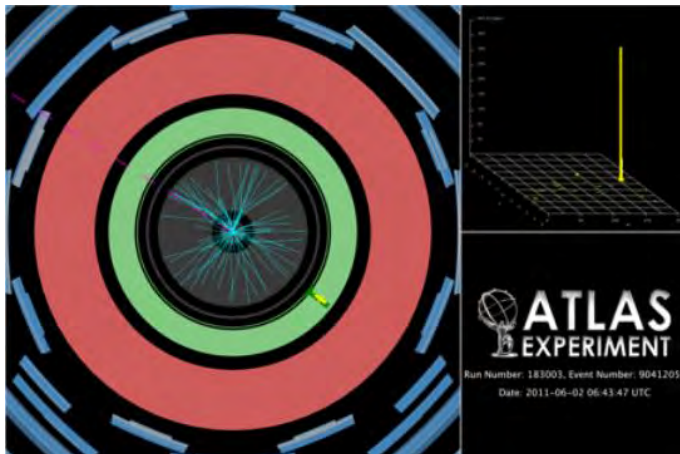

Signature: high p_T Photon + MET

CMS PRL 108, 261803 (2012)

ATLAS PRL 110, 011802 (2013)

2011 pp data at $\sqrt{s} = 7$ TeV

2011 result
Stay tuned for
2012 update

Signal and Background

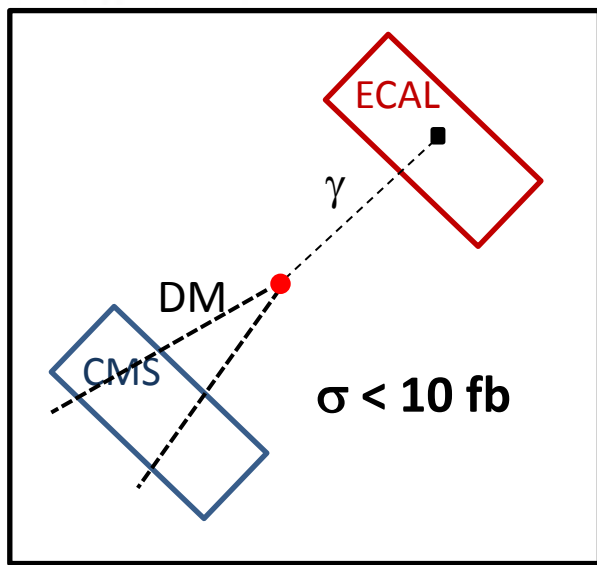
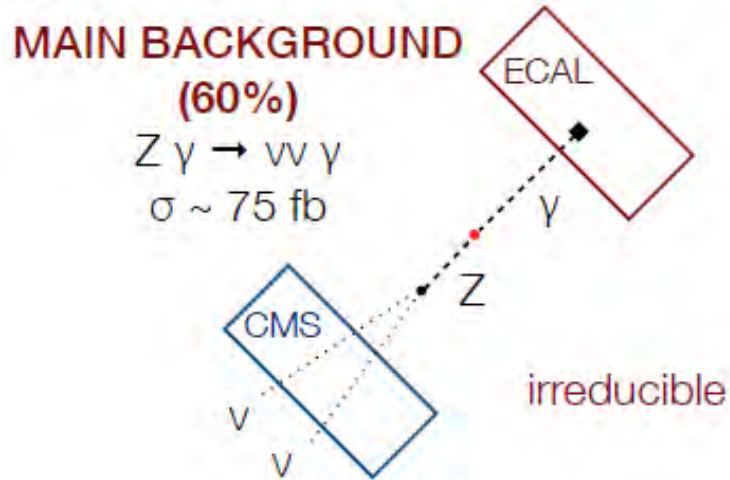
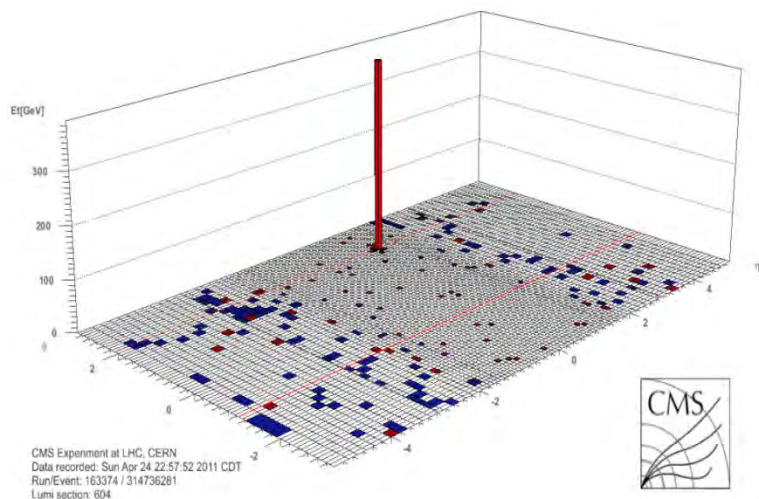

Several Other Backgrounds

OTHER BACKGROUNDS

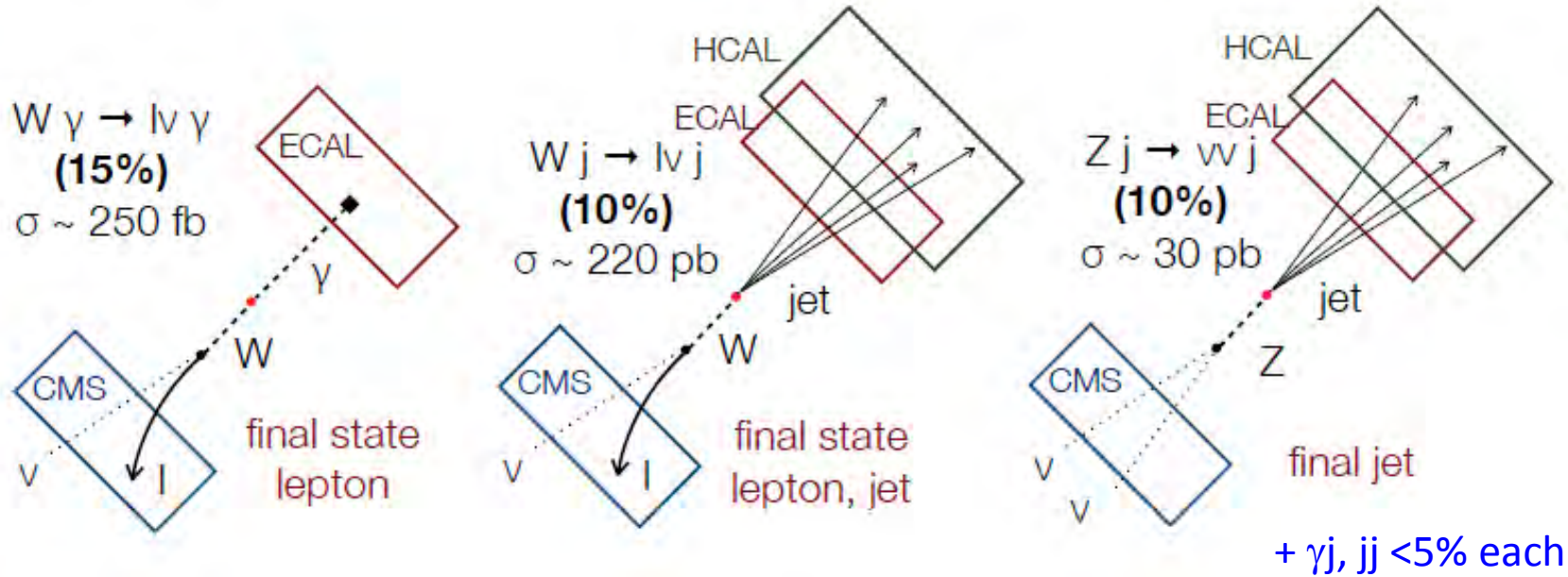

Instrumental backgrounds (~30%) from mis-identification and beam halo

SM backgrounds (~70%):

- Needs good understanding of cross section for $Z\gamma$, $W\gamma$.
- NLO corrections. NLO k-factor (1.3 global SF for $W\gamma$, $p_T(\gamma)$ dependant SF for $Z\gamma$ (~1.5 global))

Source	Estimate
Jet Mimics Photon	11.2 ± 2.8
Beam Halo	11.1 ± 5.6
Electron Mimics Photon	3.5 ± 1.5
$W\gamma$	3.0 ± 1.0
γ +jet	0.5 ± 0.2
$\gamma\gamma$	0.6 ± 0.3
$Z(\nu\bar{\nu})\gamma$	45.3 ± 6.9
Total Background	75.1 ± 9.5
Total Observed Candidates	73

Monophoton Result

CMS PRL 108, 261803 (2012)
ATLAS PRL 110, 011802 (2013)

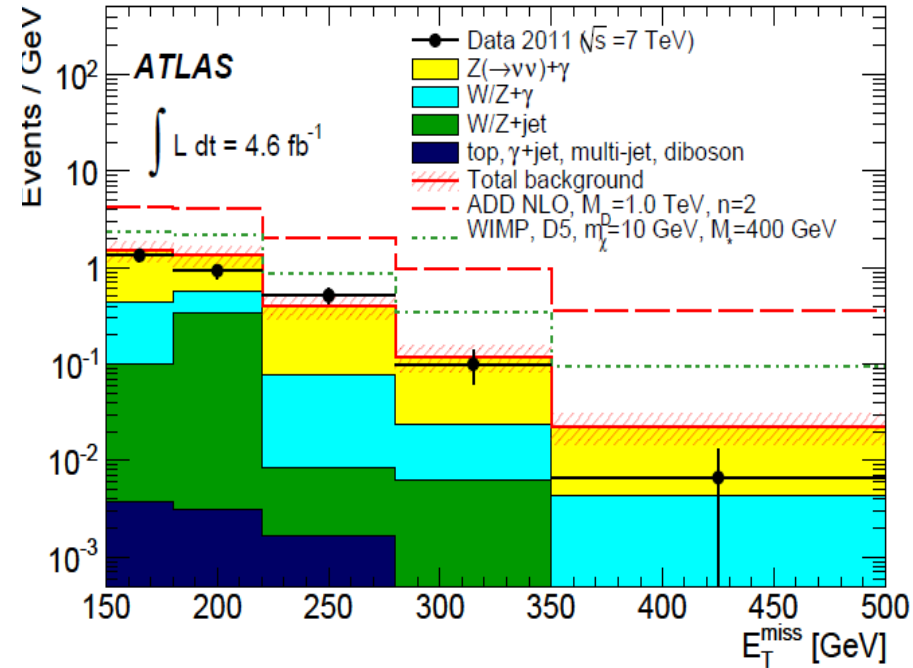
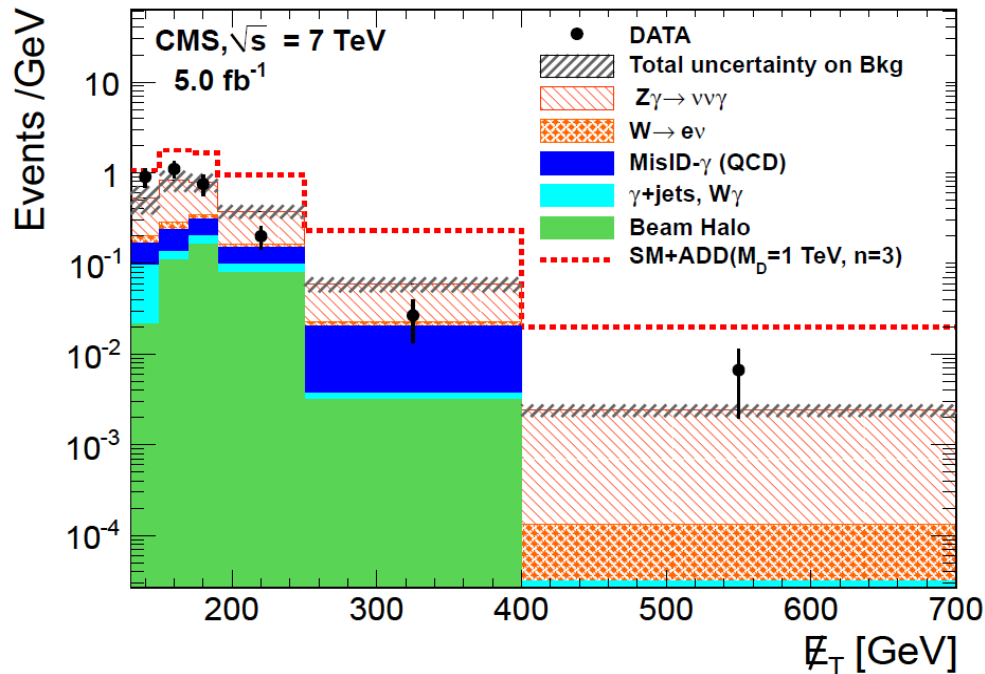

Good agreement with SM in both analyses

- ATLAS Exp. 137 ± 20 Obs. 116
- CMS Exp. 75.1 ± 9.5 Obs. 73

ATLAS Monojet 2011
Exp. 2180 ± 170
Obs. 2353

DM-Nucleon Cross Section

CMS PRL 108, 261803 (2012)
ATLAS PRL 110, 011802 (2013)

Model-independent 90% CL upper limits on cross section

2011 data

14 fb (V and AV) for $M_\chi < 200$ GeV $\rightarrow \Lambda > 570$ GeV

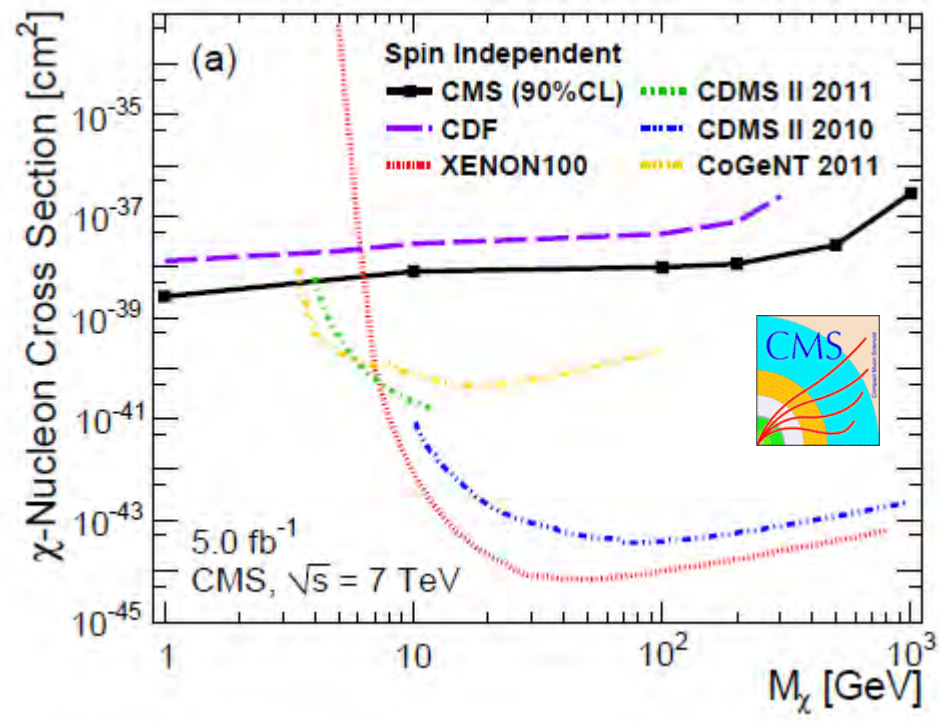
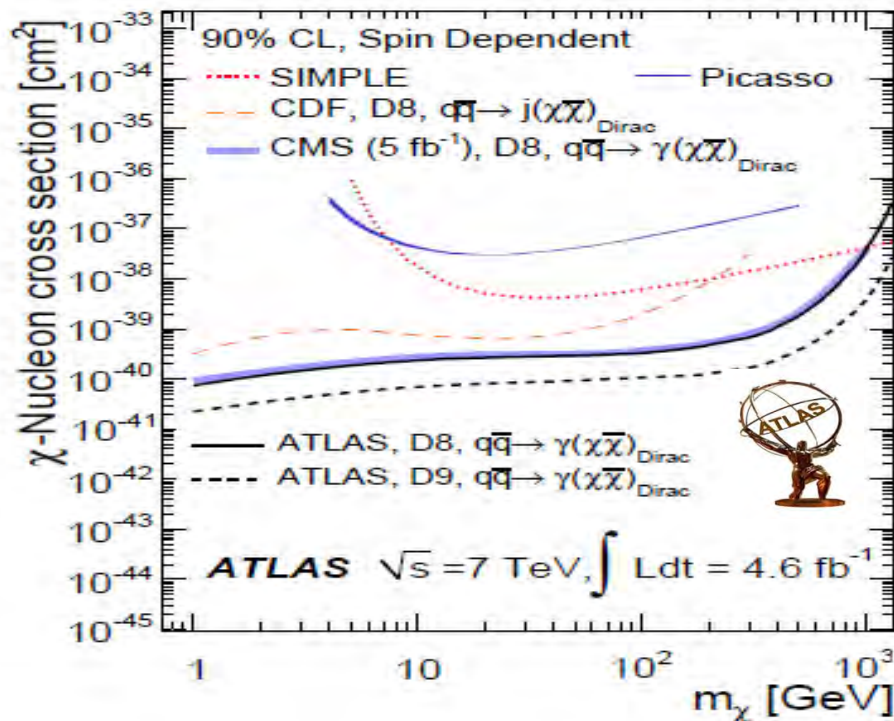

ATLAS and CMS comparable results at 7 TeV.

With 8 TeV statistics expect 10x higher sensitivity.

Search for Pair Produced Dark Matter in **Monolepton** Channel

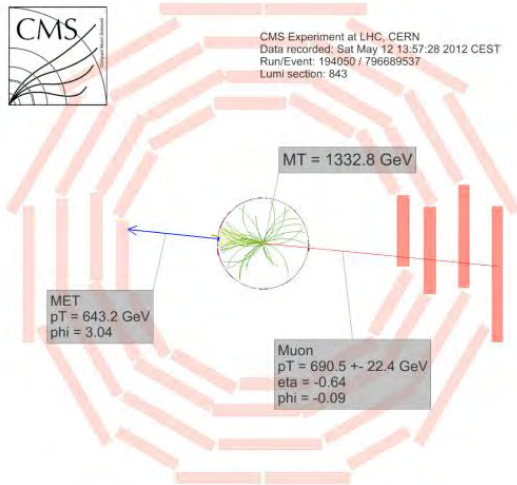
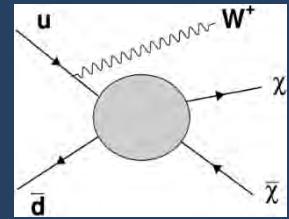

**New 2012
legacy result**

Signature W + MET:

high p_T electron + MET

High p_T muon + MET

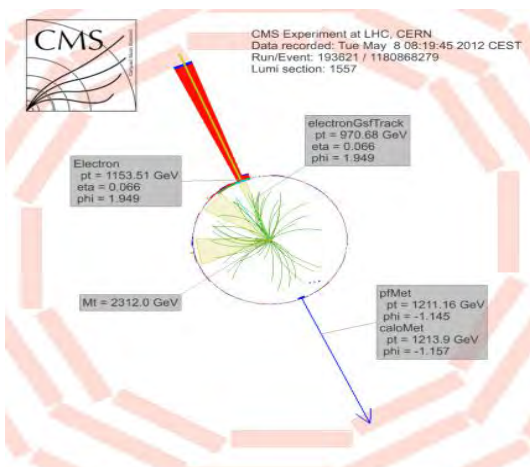

CMS –PAS-EXO-13-004

20/fb of 2012 pp data at $\sqrt{s} = 8$ TeV

Search strategy following
Bai and Tait: arXiv:1208.4861v2

Interference

Mono-jet/photon channel insensitive to quark type

For W possibly different coupling to u- and d-type quarks

if [$C(u) = C(d)$] \rightarrow destructive interference

if [$C(u) = -C(d)$] \rightarrow constructive interference \rightarrow mono-boson more sensitive than mono-jet

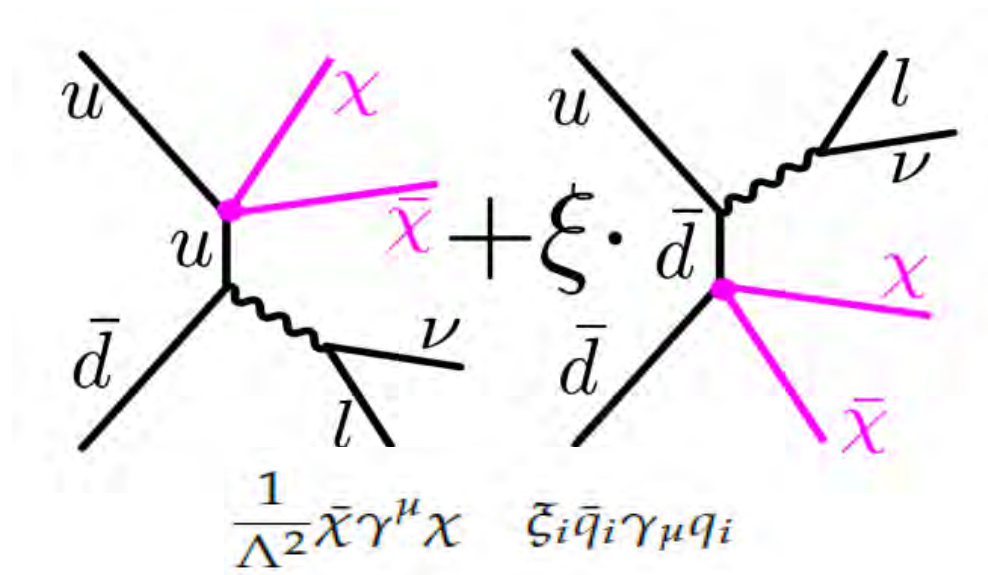

Neutrino + DM
contribute to
MET

Interference Parametrized by $\xi = -1, 0, +1$

Mono-jet $\xi=+1$

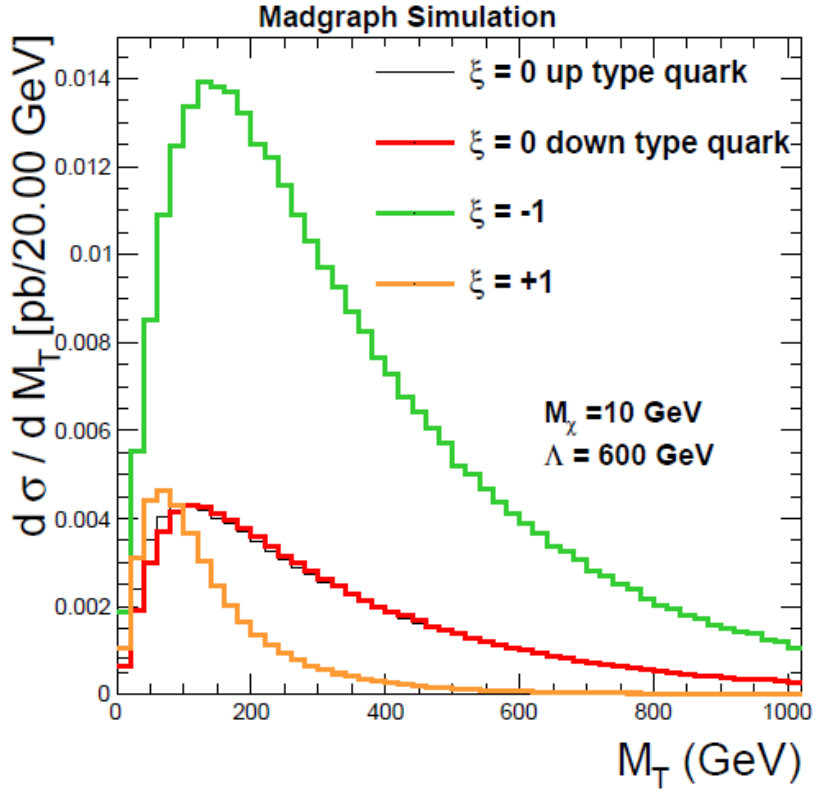
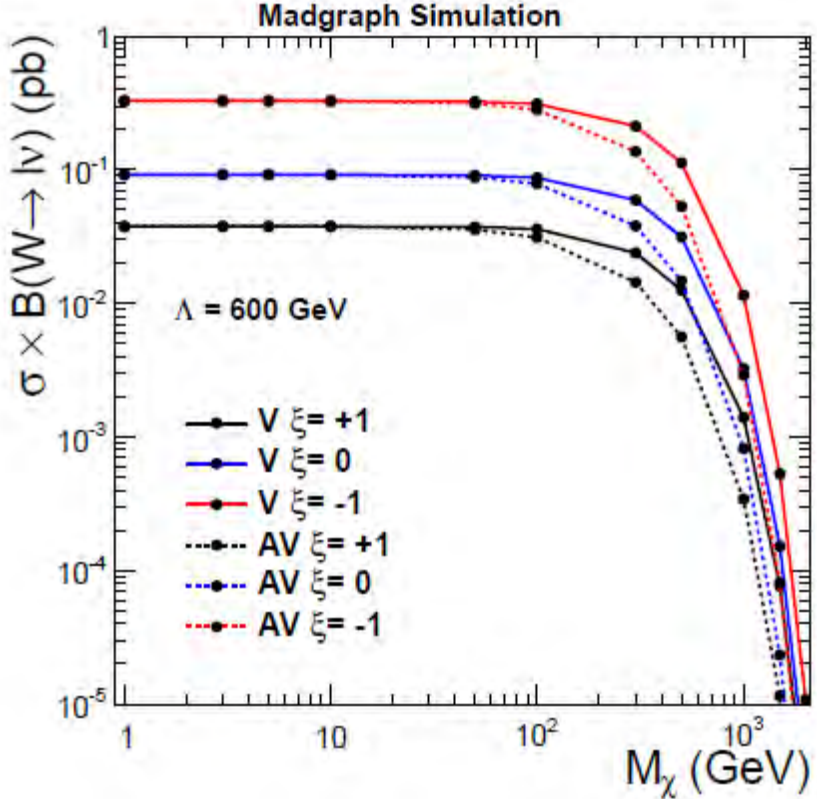

Largest cross section for $\chi = -1$
 For $M_\chi < \sim 70$ GeV same cross section
 for V and AV coupling of fixed ξ

Interference type influences
 M_T shape \rightarrow impact on
 sensitivity

Selecting Monolepton Events

CMS-PAS-EXO-13-004

Event selection

- Single electron(muon) trigger with $p_T > 85(40)$ GeV
 - Lepton ID optimized for high p_T
 - Kinematical selections:
 - $0.4 < p_T / MET < 2$
 - $\Delta\phi < 0.8$
- Search strategy for lepton +MET following Bai & Tait: arXiv:1208.4361

Transverse mass distribution

$$M_T = \sqrt{2 \cdot p_T^\ell \cdot E_T^{\text{miss}} \cdot (1 - \cos \Delta\phi_{\ell, \nu})}$$

Background

- Derived from simulation
- Challenge high M_T tail
- Main bkgr: $W \rightarrow l\nu$ with M_T binned k-factor
- NLO xsec's

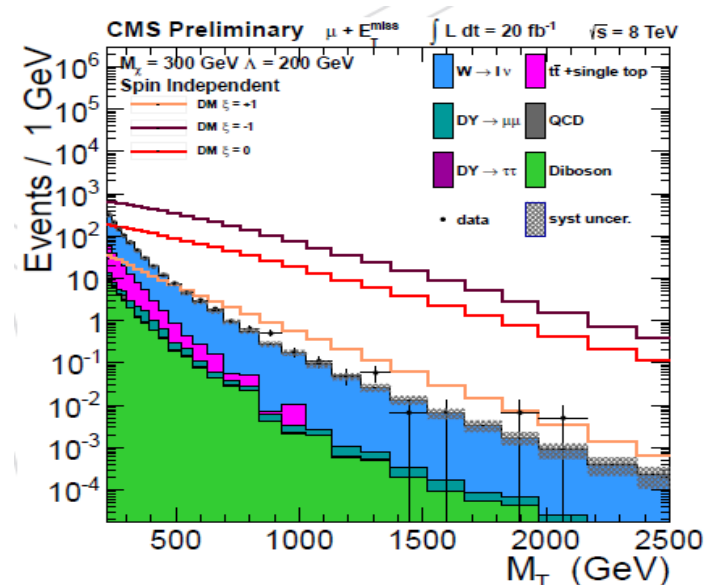
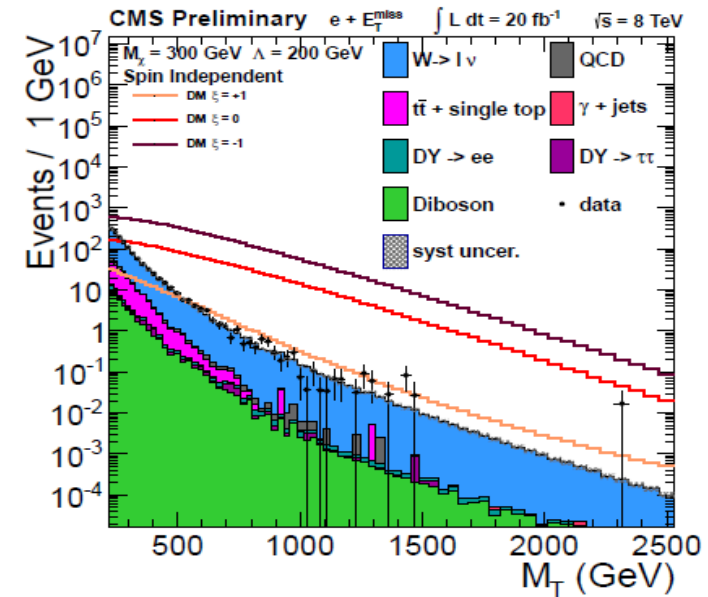

Challenge of TeV Leptons

Heavy particles yield final state leptons with high momentum \rightarrow dedicated reconstruction algorithms (especially for $l+\text{MET}$)

Muons $E_{\text{critical}} \sim 900 \text{ GeV} \rightarrow$ **Muon shower** (in CMS return yoke, $\sim 10 X_0$)

1 TeV muon with a "catastrophic" energy loss of 22 GeV

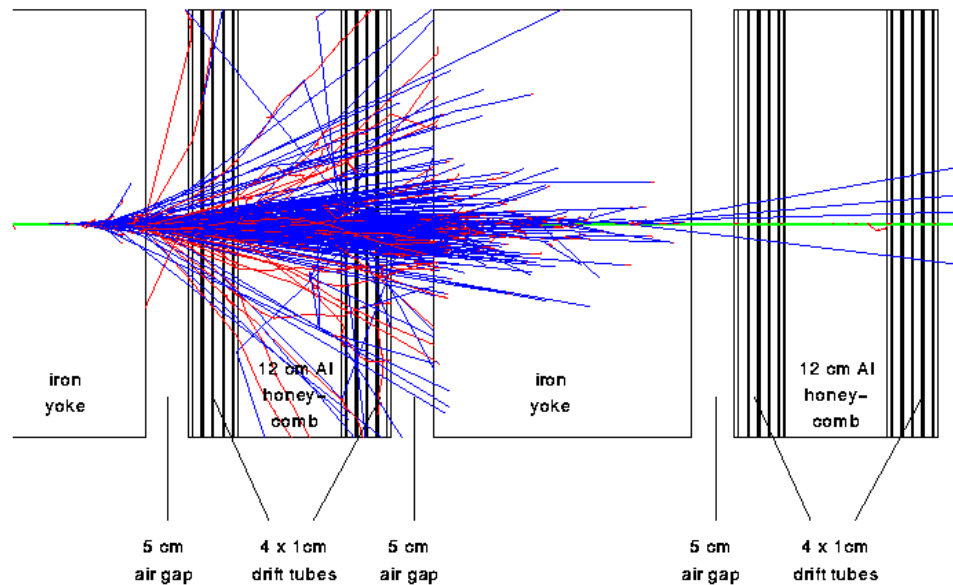

Limits on production cross section + λ

V
Spin
In-
depen-
dent

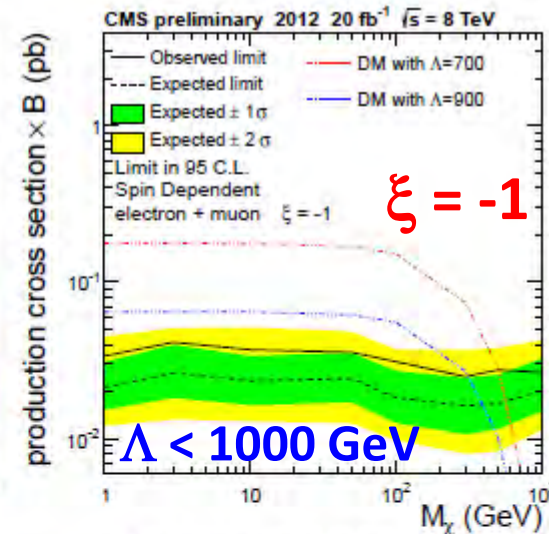
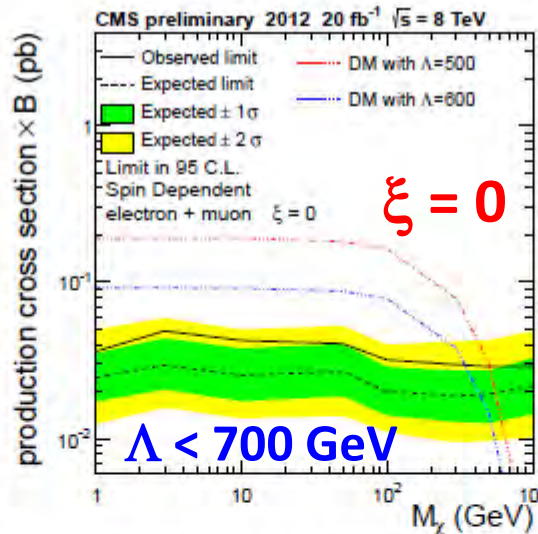
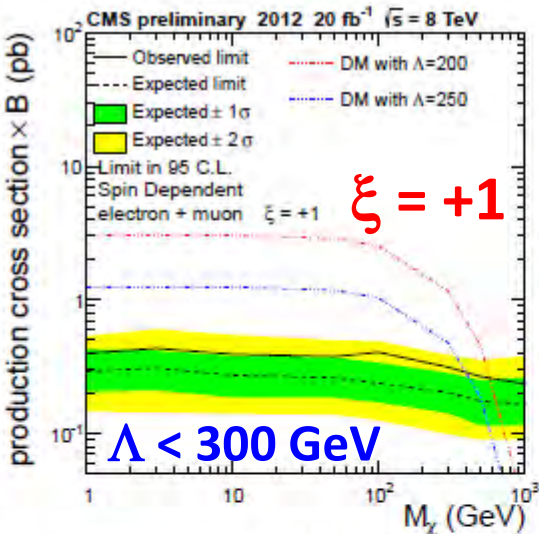

AV
Spin
depen-
dent

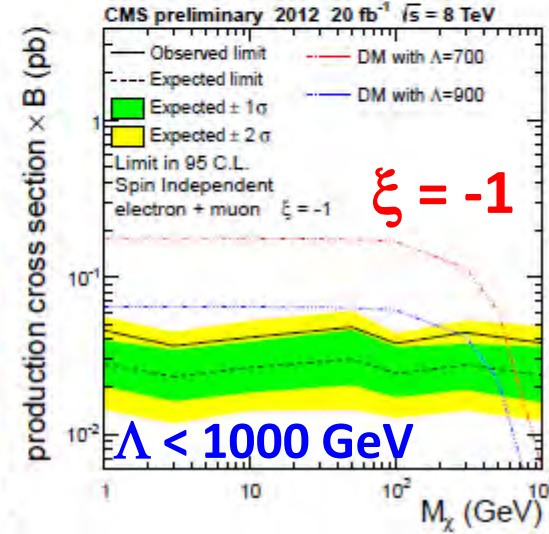
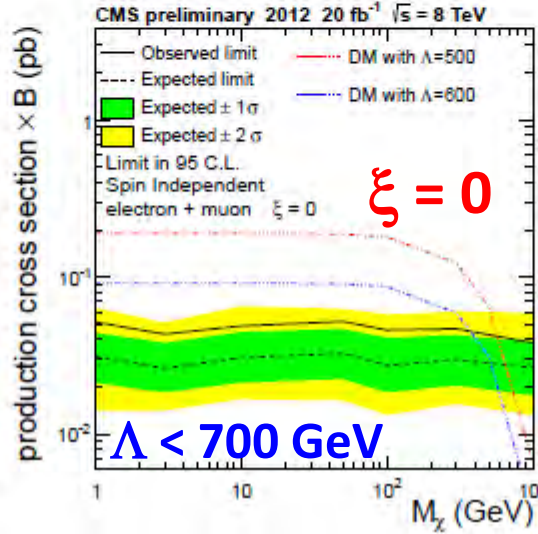
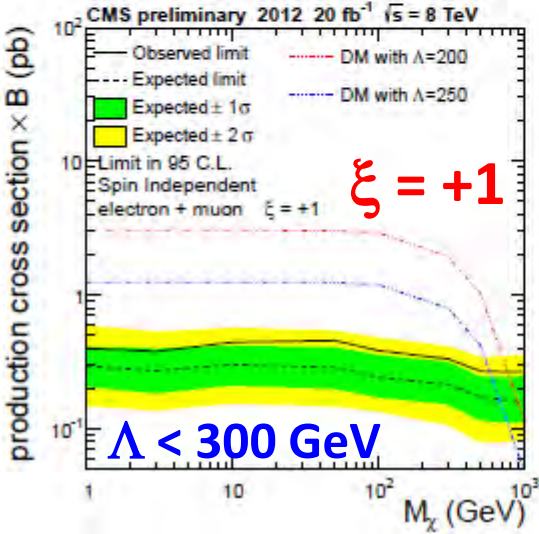

Translation to DM-Nucleon

Same procedure as for monojet. Standard assumption is $\xi=+1$

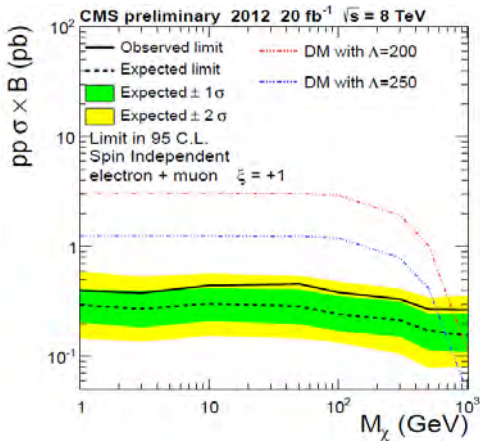

Vector operator

$$\frac{1}{\Lambda^2} \bar{\chi} \gamma^\mu \chi \quad \bar{\xi}_i \bar{q}_i \gamma_\mu q_i$$

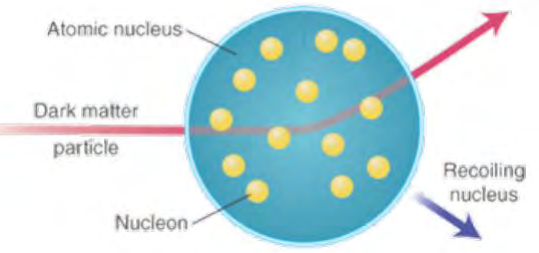
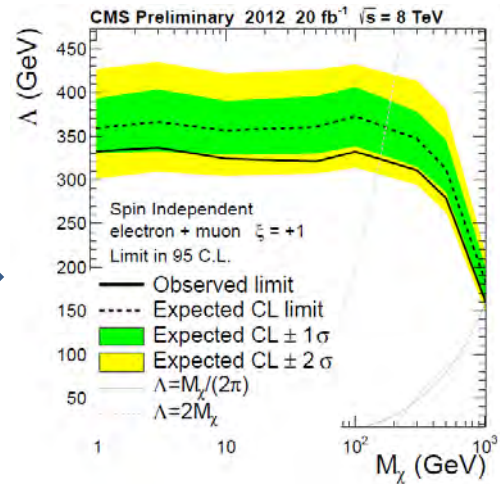

Spin-Independent

$$\mathcal{O}^N = f_q^N \frac{(\bar{N} \gamma^\mu N) (\bar{\chi} \gamma_\mu \chi)}{\Lambda^2}$$

Coefficient relating nucleon and quark operator

Channel	Lambda limit for Mchi < 200 GeV
I+MET $\xi = +1$	300 GeV
I+MET $\xi = 0$	700 GeV
I+MET $\xi = -1$	1000 GeV
Jet + MET	900 GeV

ξ
 with $f_u^p = f_d^n = 2, f_d^p = f_u^n = 1$
 $f = 0$ for other quarks
 arXiv:0803.2360.

$$\sigma_{SI} = \frac{\mu^2}{\pi \Lambda^4} \left(\sum_q f_q^N \right)^2$$

Monolepton $\xi = -1$ (max. sensitivity)

CMS-PAS-EXO-13-004

2012 results in comparison to monojet and some direct detection experiments, 90% C.L.

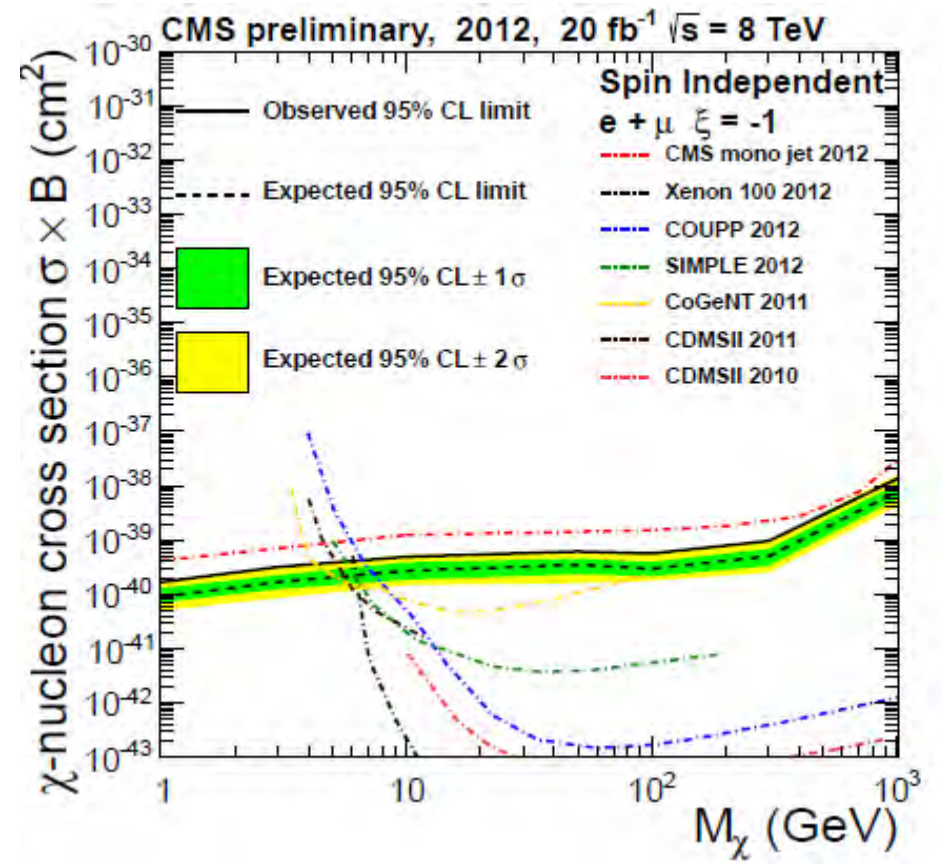
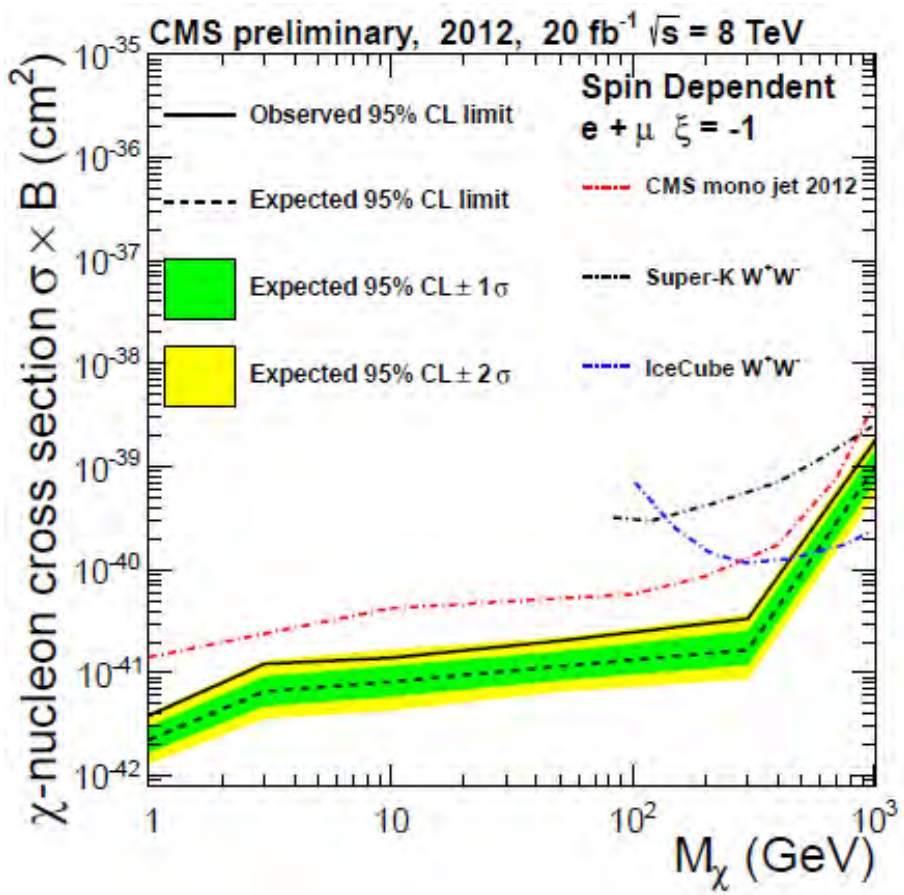

New 2012
legacy result

Hadronically Decaying W/Z

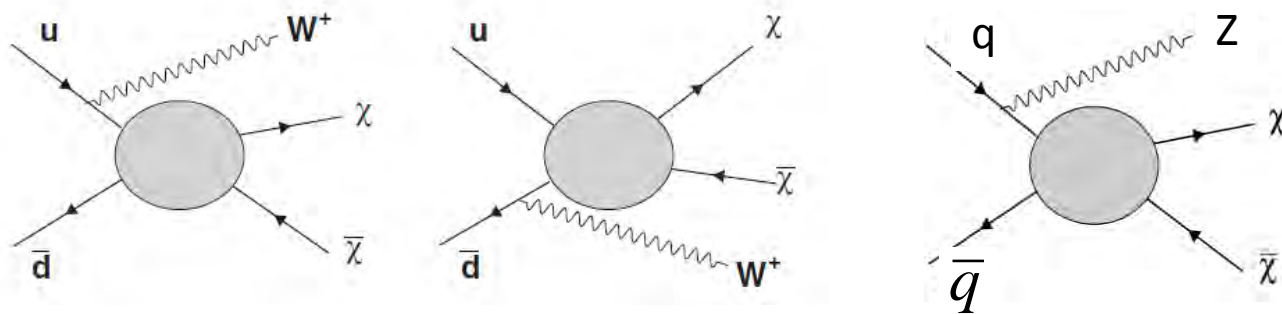

Signature W or Z + MET: two merged jets + MET

Use hadronic decays with large BR ($\sim 70\%$). Resulting final states (W/Z) cannot be distinguished.

W is sensitive to interference = different u/d couplings.

[also a search
for WH, ZH
with $H \rightarrow \chi\chi$]

ATLAS-CONF-13-073 (PRL 112 (041802))

20/fb of 2012 pp data at $\sqrt{s} = 8$ TeV

Hadronically Decaying W/Z

ATLAS paper on jet sub-structure arXiv:1306.4945

Increasing rate of overlapping jets \rightarrow Reconstructed as one „large-radius“ jet with Cambridge-Aachen algorithms:

- Step a: **Splitting** in two subjets (mass-drop filtering procedure)
- Step b: **Filtering**, reclustering 3 jets with C/A
- Step c & d: **Trimming and pruning**

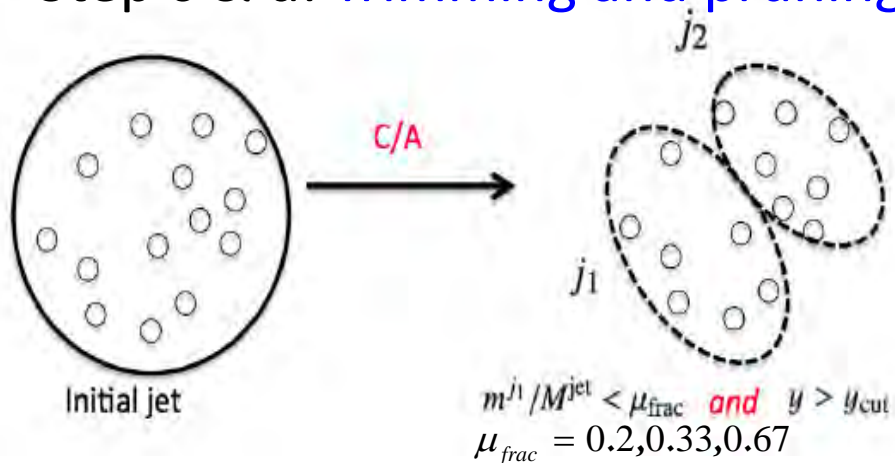

Split in 2 sub-jets j_1, j_2 with $m^{j1} < m^{j2}$

Splitting approx. symmetric in energy sharing and opening angle.

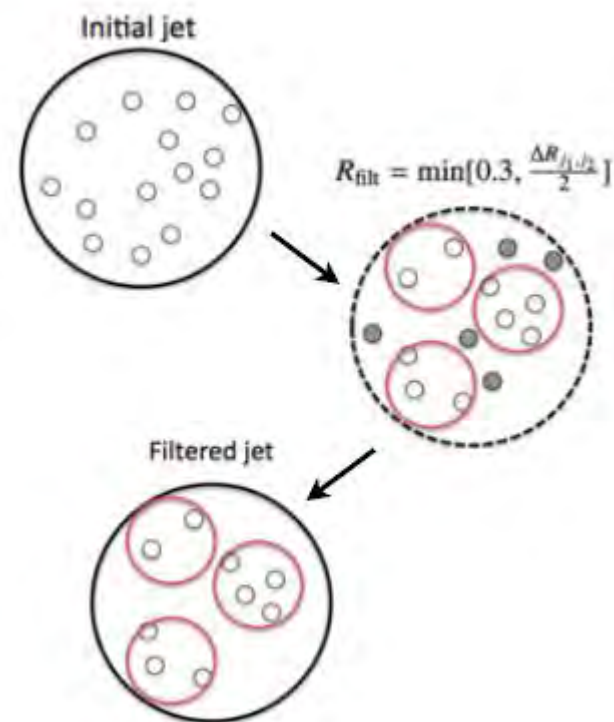

Search Performed in MET Distribution

Main Background $Z(\nu\nu)+\text{jets}$ 60%, $W(l\nu)+\text{jets}$ 30%

Data agree with SM expectation

Control regions $Z \rightarrow \mu\mu$, $W \rightarrow \mu\nu$

Two signal regions:

$\text{MET} > 350 \text{ GeV}$

$\text{MET} > 500 \text{ GeV}$

Dominating syst. uncertainties:

- limited statistics in control samples,
- theo.uncertainties in samples used for extrapolations,
- jet and MET reconstruction

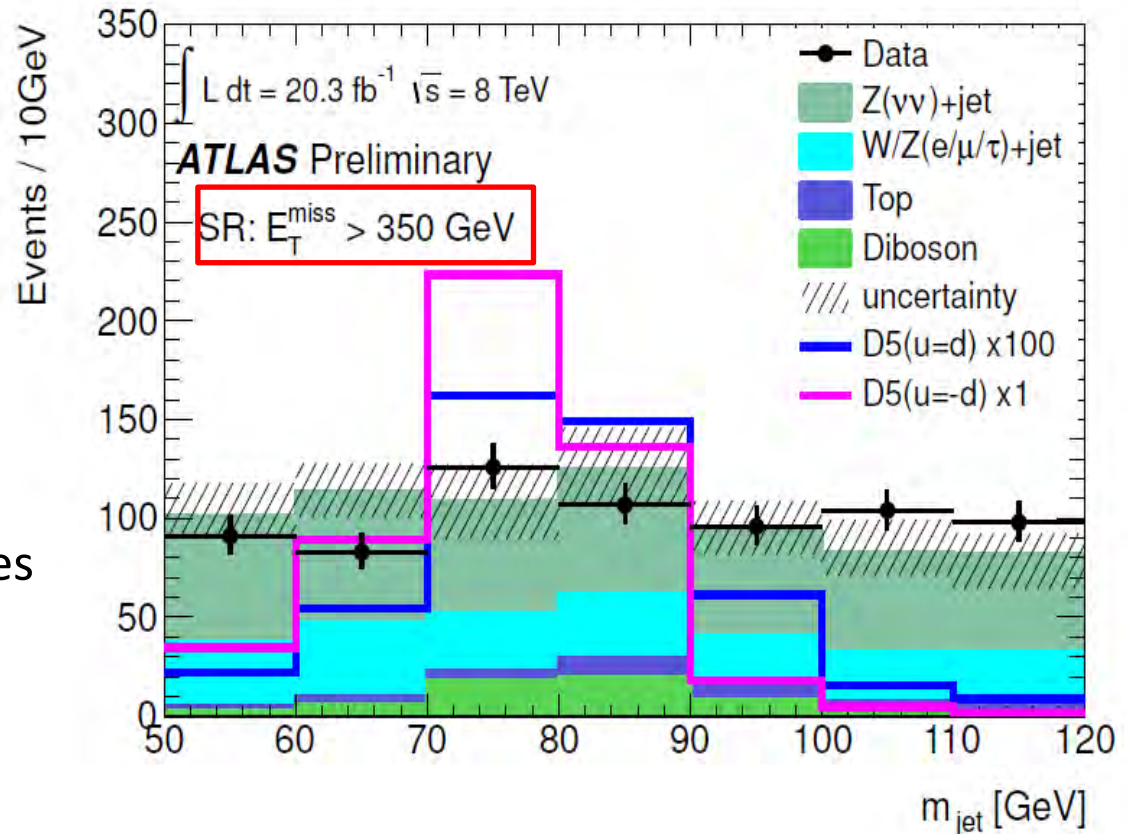

Mono-W/Z Limits

Using predicted **shape** of M_{jet} distribution in each signal region
 CLs method

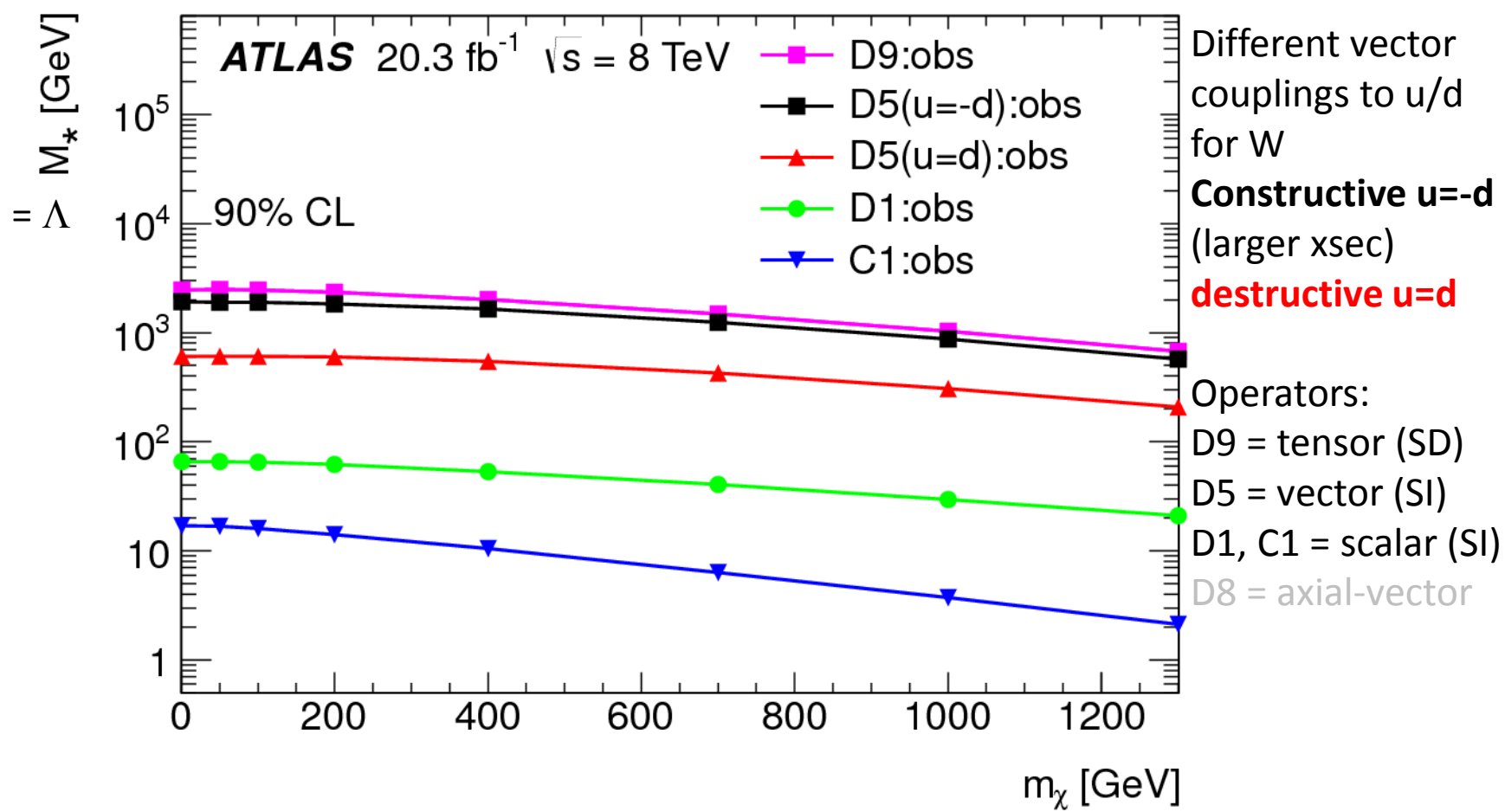

Mono-W/Z in the χ -N plane

Spin-independent limits very strong
 10^{-42} cm^2 for vector coupling when
 u & d have opposite sign

Set strong spin-dependent limits
 10^{-43} cm^2 for tensor operator

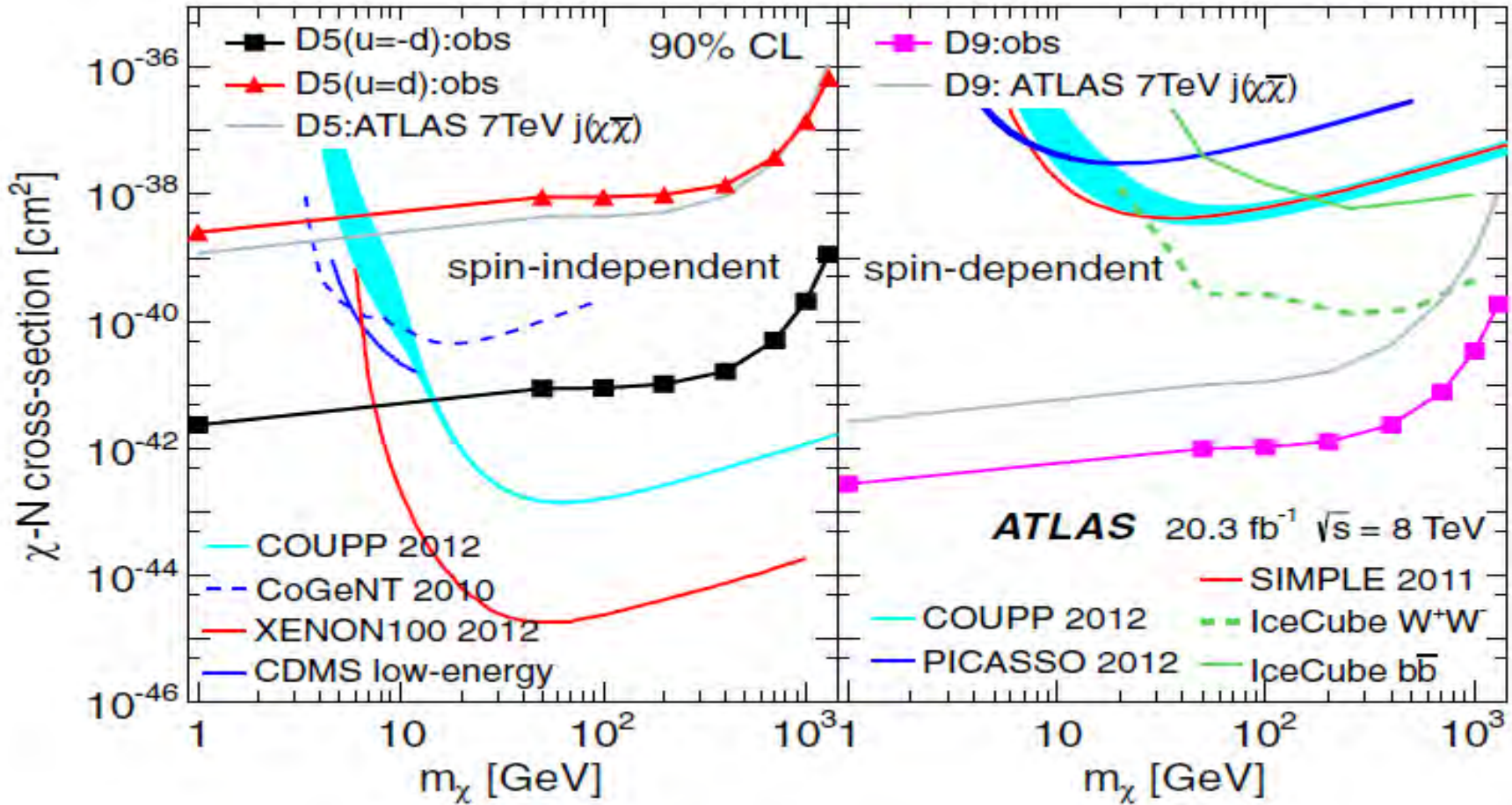

The Big (LHC) Picture...



All 2012 Mono-X Together

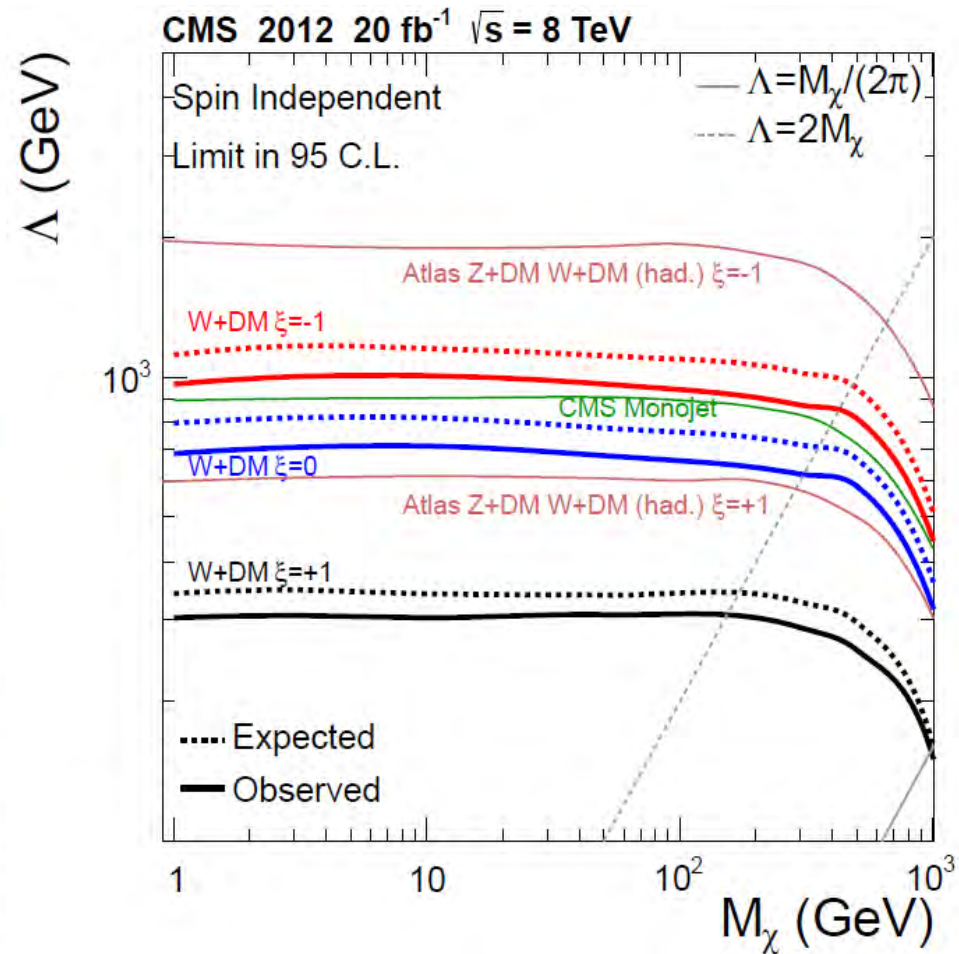
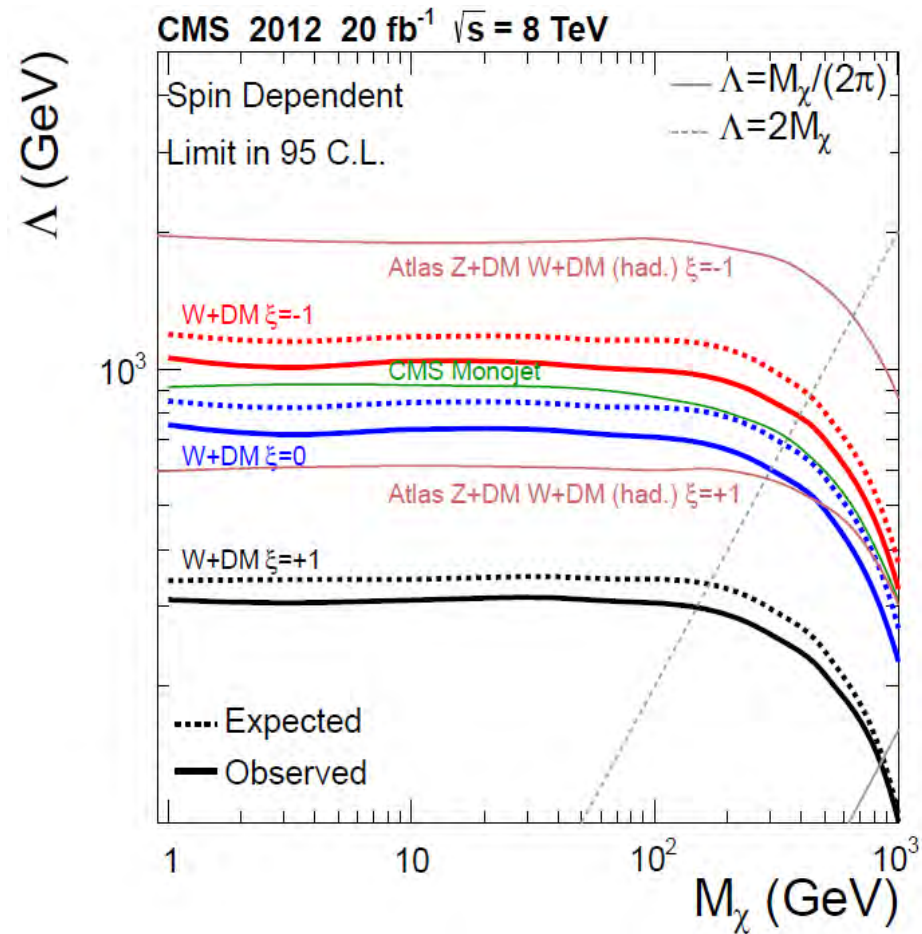

Effective theory valid up to $\Lambda < 2 M_\chi$

What's Next?

- Signature oriented searches **strongly supported by theory**
- **Extend** simple contact interaction, more operators, Discussions with theorists, [\[http://kicp-workshops.uchicago.edu/DM-LHC2013/index.php\]](http://kicp-workshops.uchicago.edu/DM-LHC2013/index.php)
- **Scan over mediator mass** (CMS monojet analysis)
- Consider **limitations of EFT**. Good/conservative results above a few hundred GeV.

CMS-PAS-EXO-12-048 (20/fb)

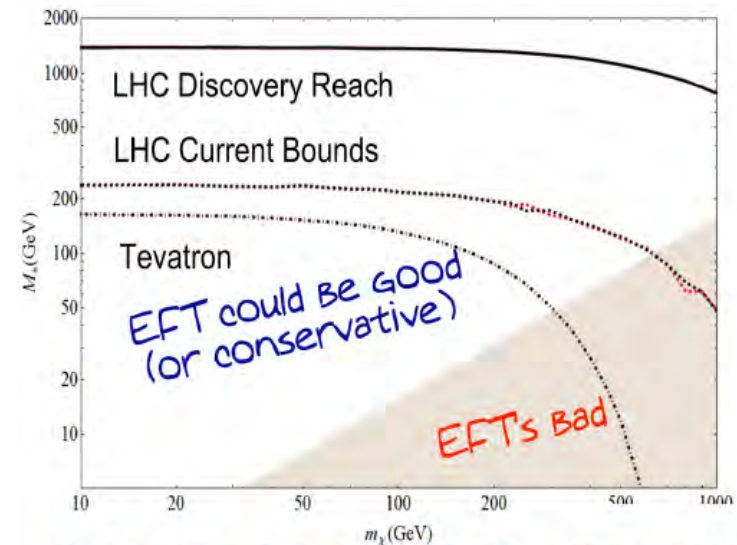
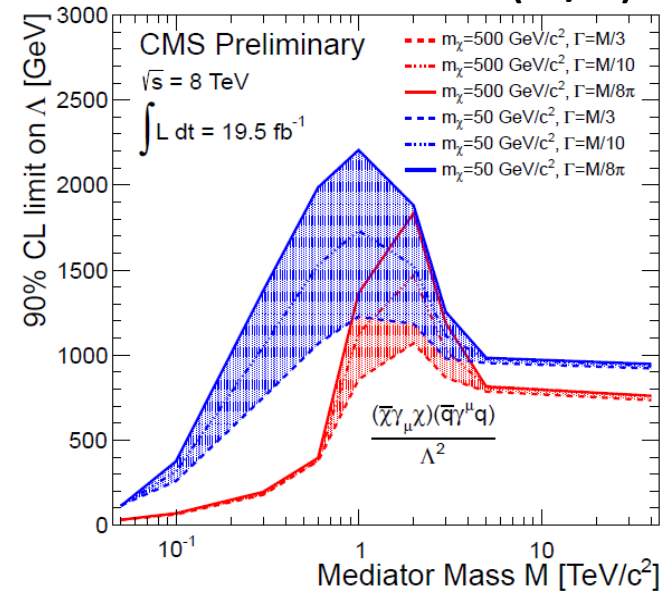

[from R. Harnik, Dark Matter in Collision, UC Davis, 2012]

What Can We Reach at 14 TeV?

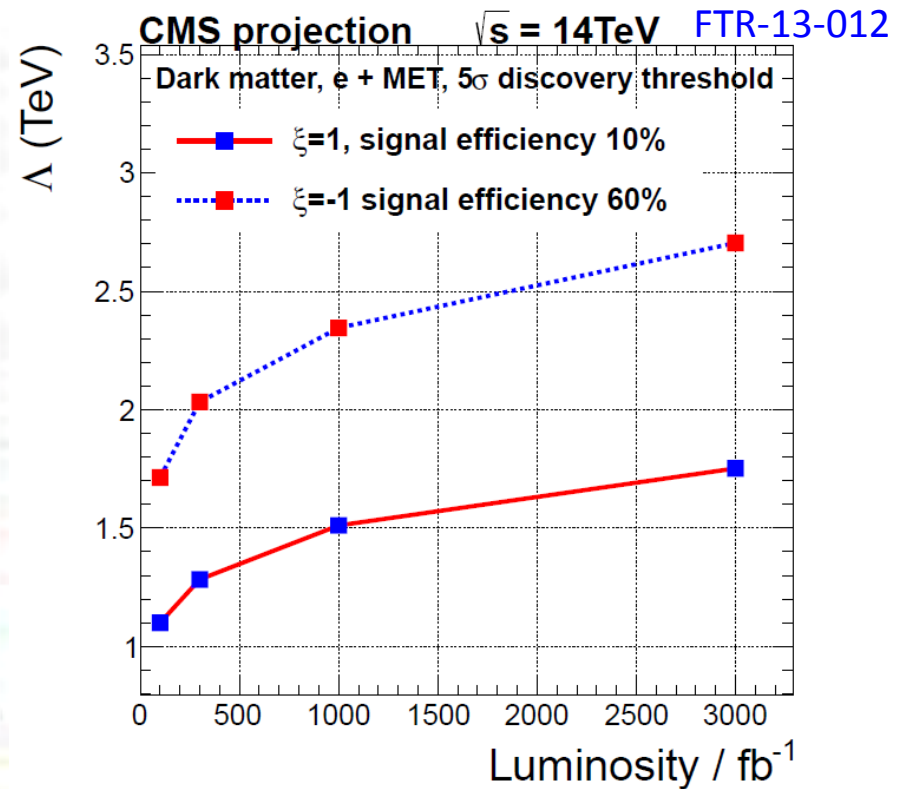
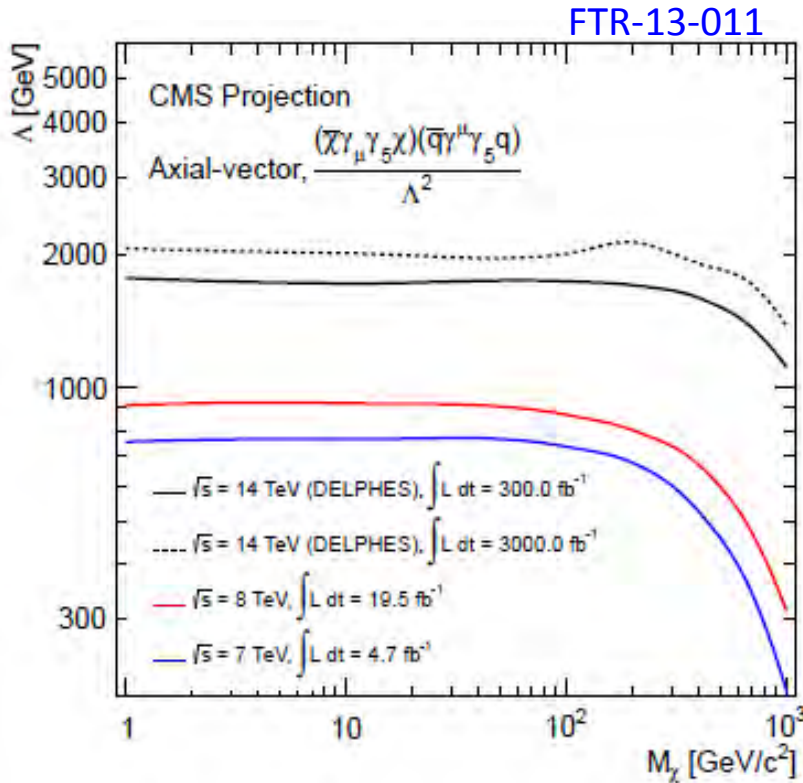

Gain sensitivity with increasing sqrt(s).

At 14TeV and 300/fb. Reach in lambda O(x2)

Main challenge MET in high PU.

Summary

<https://twiki.cern.ch/twiki/bin/view/CMSPublic/PhysicsResultsEXO>

<https://twiki.cern.ch/twiki/bin/view/AtlasPublic/ExoticsPublicResults>

Exciting new field. Major opportunity for new physics!

Several LHC BSM searches **reinterpreted** in terms of dark matter models.

Work **closely with theorists** to develop theoretical assumptions and models.

Complementary to direct detection experiments. Study DM **properties** in case of discovery.

Improved sensitivity in Run-2 of the LHC.



Additional Material

Possible Couplings

Most prominent couplings

Spin-**in**dependent vector coupling (V)

$$\frac{1}{\Lambda^2} \bar{\chi} \gamma^\mu \chi \quad \xi_i \bar{q}_i \gamma_\mu q_i$$

Spin-**de**pendent axial-vector coupling (AV)

$$\frac{1}{\Lambda^2} \bar{\chi} \gamma^\mu \gamma^5 \chi \quad \xi_i \bar{q}_i \gamma_\mu \gamma^5 q_i$$

Name	Type	Operator	Coefficient
D1	scalar (qq)	$\bar{\chi} \chi \bar{q} q$	m_q / M_*^3
D5	vector	$\bar{\chi} \gamma^\mu \chi \bar{q} \gamma_\mu q$	$1 / M_*^2$
D8	axial-vector	$\bar{\chi} \gamma^\mu \gamma^5 \chi \bar{q} \gamma_\mu \gamma^5 q$	$1 / M_*^2$
D9	tensor	$\bar{\chi} \sigma^{\mu\nu} \chi \bar{q} \sigma_{\mu\nu} q$	$1 / M_*^2$
D11	scalar (gg)	$\bar{\chi} \chi G_{\mu\nu} G^{\mu\nu}$	$\alpha_s / 4 M_*^3$
C1	scalar	$\chi^\dagger \chi \bar{q} q$	m_q / M_*^2

According to [J. Goodman et al., Phys. Rev D 82, 116010 (2010)]

The masses of strange and charm quarks are relevant for the cross sections of the D1 operator and they are set to 0.1 GeV and 1.42 GeV, respectively.

Lux Result

Spin-independent sensitivity

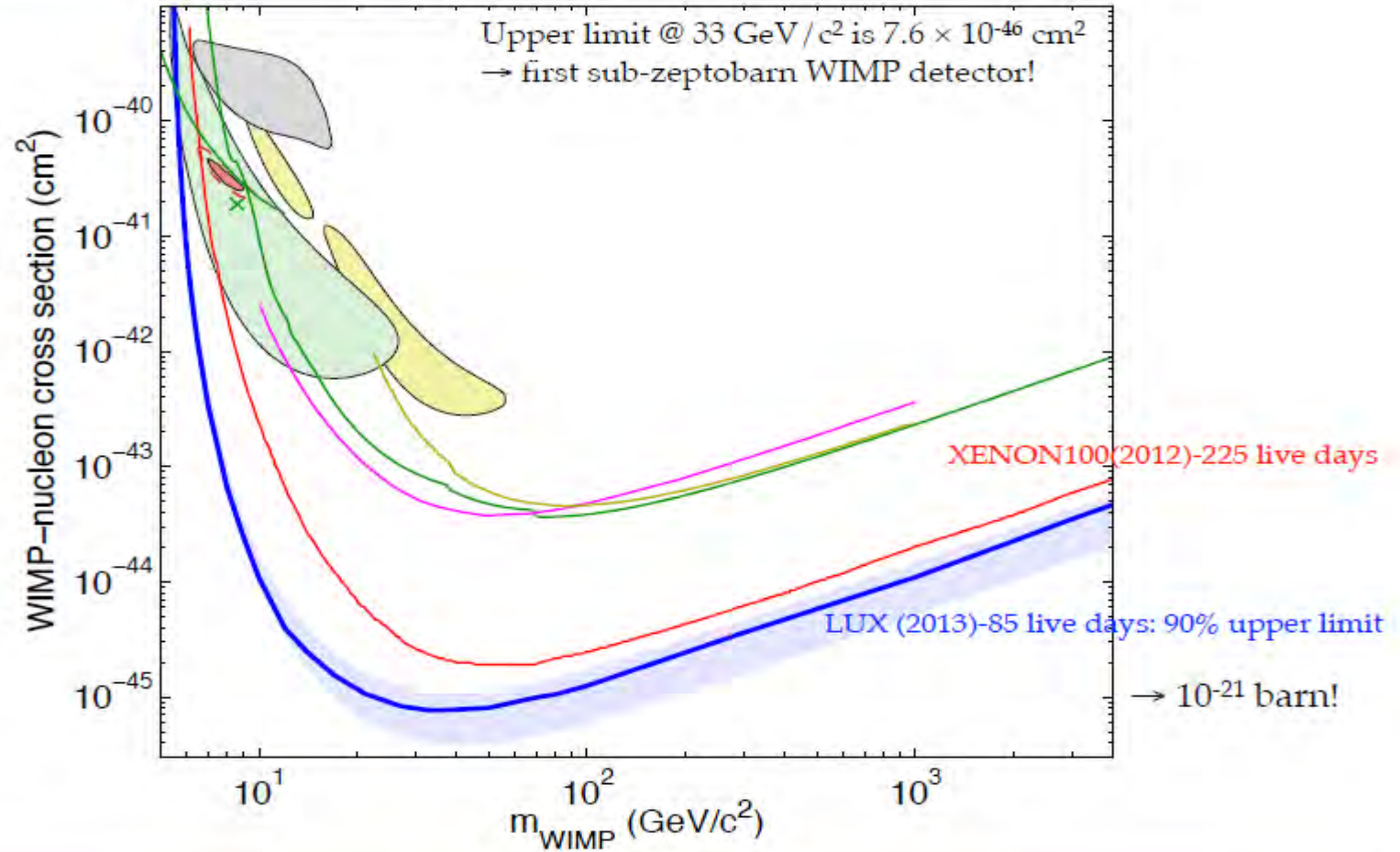

High Energy Electron Selection



CMS Experiment at LHC, CERN
 Data recorded: Wed Sep 21 11:35:51 2011 CEST
 Run/Event: 176841 / 213192769
 Lumi section: 189
 Orbit/Crossing: 49420229 / 1640

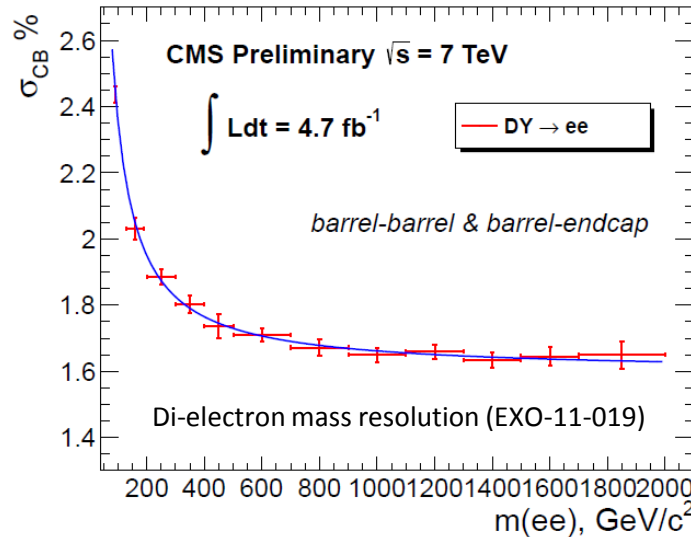
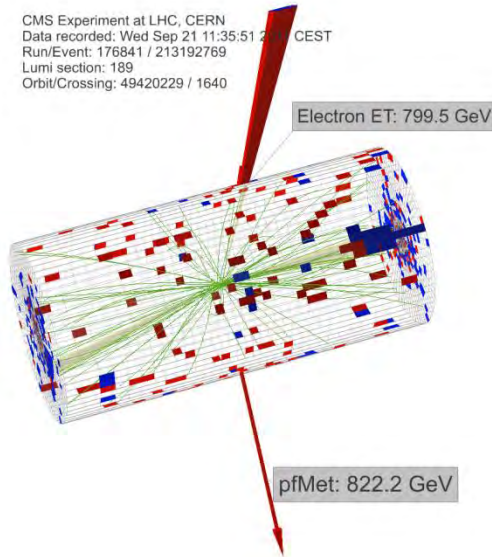

ECAL made of matrix of fully active crystals. Measured energy resolution $\sim 2\%$

Electrons are reconstructed from energy clusters in the ECAL and tracks from the silicon tracker
 Electron ID optimized for high E_T requires:

- $E_T > 85$ GeV
- $|\eta| < 1.442$ (barrel) or $1.56 < |\eta| < 2.5$ (endcap)
- Good quality of track and cluster
- Matching between the two
- Isolation

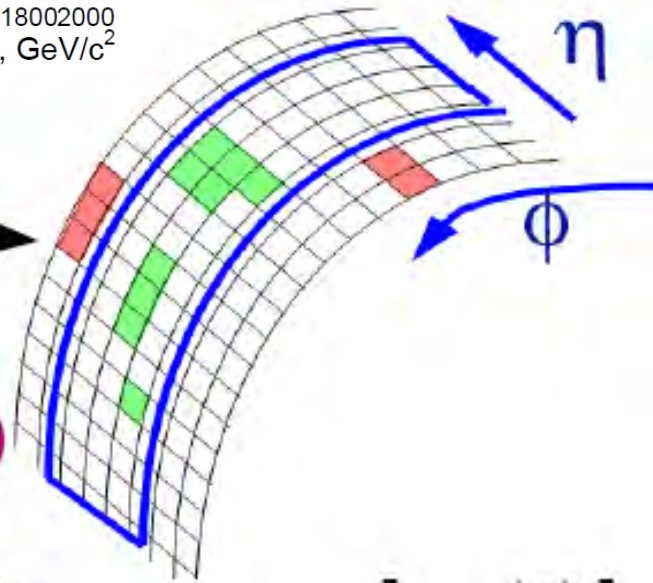

$$\eta = -\ln \left[\tan \left(\frac{\theta}{2} \right) \right]$$

High p_T Muon Selection

High redundancy of mu system, 4 stations along track
Iron between stations may cause **bremstrahlung**
for O(TeV) muons
 $p_T < 200$ GeV tracker in $B=3.8T$, $p_T > 200$ GeV mu+tracker

Dedicated muon selection:

- Special algorithm to consider **showering**
- At least 1 **pixel** hit
- Number of **measured tracker layers** > 8
- Transverse impact parameter $d_0 \leq 0.2\text{cm}$
(Z'), **0.02cm** (W') reject cosmics, value for W' tighter than other analyses, Z' rejects in addition back-to-back muons
- ≥ 2 matched **muon** segments
- Relative track **isolation** < 0.10 in $\Delta R < 0.3$
- No cut on **chi2** cut introduces a 4-6% inefficiency for muons > 500 GeV

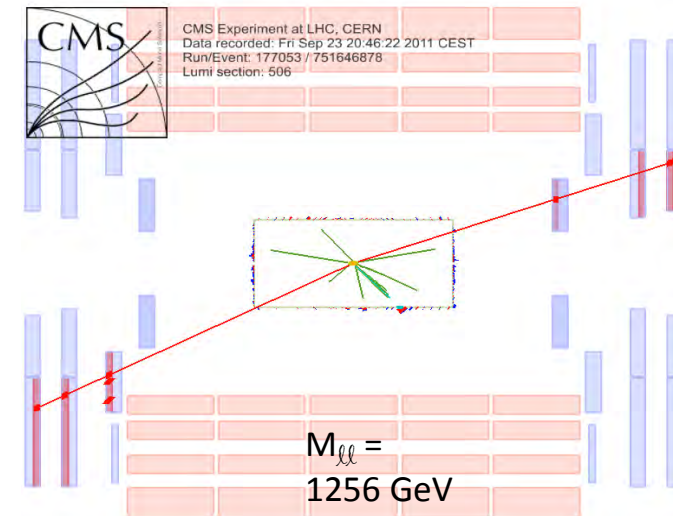
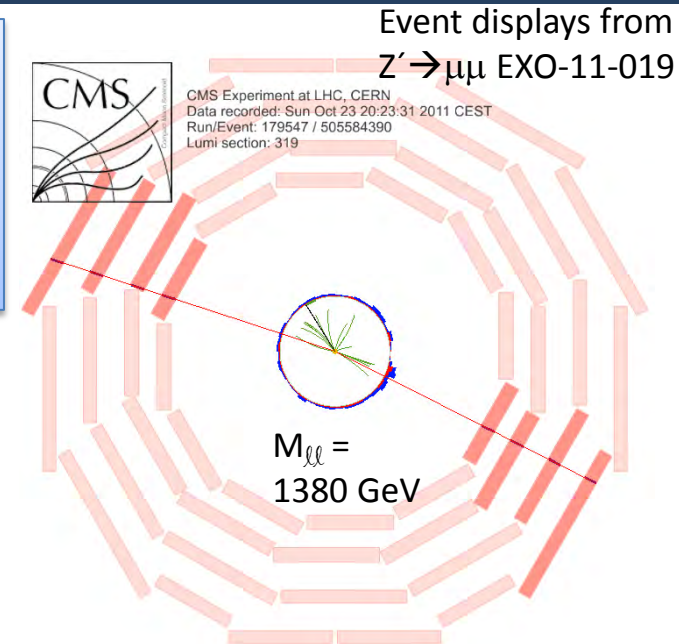

Photon identification



✓ Background contamination and invariant mass resolution depends on:

- pseudorapidity
- cluster shape, i.e. conversion probability (R_9)

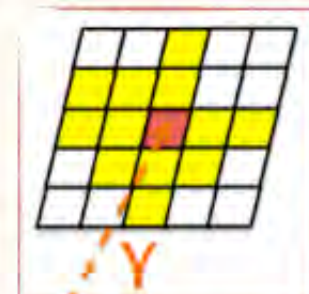

✓ Same approach like $H \rightarrow \gamma\gamma$ standard cut-based **photon-ID**

- ECAL fiducial region ($|\eta| < 2.4$ excluding EB-EE gap)
- Isolation and identification requirements:

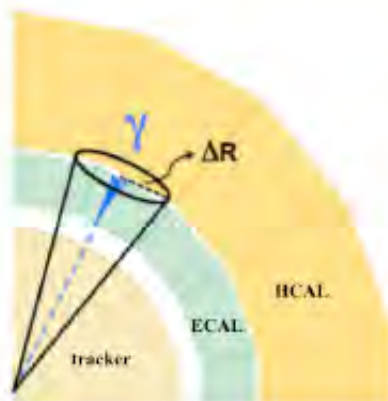

	barrel		endcap	
	$R_9 > 0.94$	$R_9 < 0.94$	$R_9 > 0.94$	$R_9 < 0.94$
PF isolation sum, chosen vertex	6	4.7	5.6	3.6
PF isolation sum worst vertex	10	6.5	5.6	4.4
Charged PF isolation sum	3.8	2.5	3.1	2.2
$\sigma_{i\eta i\eta}$	0.0108	0.0102	0.028	0.028
H/E	0.124	0.092	0.142	0.063
R_9	0.94	0.298	0.94	0.24